

Lanner

Network Appliance Platform

Hardware Platforms for Network Computing

NCA-5530 User Manual

Version: 1.6

Date of Release:2025-08-07

About this Document



This manual describes the overview of the various functionalities of this product, and the information you need to get it ready for operation. It is intended for those who are:

- responsible for installing, administering and troubleshooting this system or Information Technology professionals.
- assumed to be qualified in the servicing of computer equipment, such as professional system integrators, or service personnel and technicians.

The latest version of this document can be found on Lanner’s official website, available either through the product page or through the [Lanner Download Center](#) page with a login account and password.

Icon Description

The icons are used in the manual to serve as an indication of interest topics or important messages.

Icon	Usage
 Note or Information	This mark indicates that there is something you should pay special attention to while using the product.
 Warning or Important	This mark indicates that there is a caution or warning and it is something that could damage your property or product.

Online Resources

To obtain additional documentation resources and software updates for your system, please visit the [Lanner Download Center](#). As certain categories of documents are only available to users who are logged in, please be registered for a Lanner Account at <http://www.lannerinc.com/> to access published documents and downloadable resources.

Technical Support

In addition to contacting your distributor or sales representative, you could submit a request at our [Lanner Technical Support](#) and fill in a support ticket to our technical support department.

Documentation Feedback

Your feedback is valuable to us, as it will help us continue to provide you with more accurate and relevant documentation. To provide any feedback, comments or to report an error, please email contact@lannerinc.com. Thank you for your time.

Copyright and Trademarks

This document is copyrighted © 2025 by Lanner Electronics Inc. All rights are reserved. The original manufacturer reserves the right to make improvements to the products described in this manual at any time without notice. No part of this manual may be reproduced, copied, translated or transmitted in any form or by any means without the prior written permission of the original manufacturer. Information provided in this manual is intended to be accurate and reliable. However, the original manufacturer assumes no responsibility for its use, nor for any infringements upon the rights of third parties that may result from such use.

Contact Information

Taiwan Corporate Headquarters

Lanner Electronics Inc.

7F, No.173, Sec.2, Datong Rd.
Xizhi District, New Taipei City 22184,
Taiwan

立端科技股份有限公司

221 新北市汐止區
大同路二段 173 號 7 樓
T: +886-2-8692-6060

F: +886-2-8692-6101

E: contact@lannerinc.com

USA

Lanner Electronics Inc.

47790 Westinghouse Drive
Fremont, CA 94539

T: +1-855-852-6637

F: +1-510-979-0689

E: sales_us@lannerinc.com

Europe

Lanner Europe B.V.

Wilhelmina van Pruisenweg 104
2595 AN The Hague
The Netherlands

T: +31 70 701 3256

E: sales_eu@lannerinc.com

China

Beijing L&S Lancom Platform Tech. Co., Ltd.

Guodong LOFT 9 Layer No. 9 Huinan Road,
Huilongguan Town, Changping District, Beijing
102208 China

T: +86 010-82795600

F: +86 010-62963250

E: service@ls-china.com.cn

Canada

Lanner Electronics Canada Ltd

3160A Orlando Drive
Mississauga, ON

L4V 1R5 Canada

T: +1 877-813-2132

F: +1 905-362-2369

E: sales_ca@lannerinc.com

Acknowledgment

Intel® and Intel® Celeron® are trademarks of Intel Corporation or its subsidiaries in the U.S. and/or other countries. Microsoft Windows and MS-DOS are registered trademarks of Microsoft Corp. All other product names or trademarks are properties of their respective owners.

Federal Communication Commission Interference Statement

This equipment has been tested and found to comply with the limits for a Class A digital device, pursuant to Part 15 of FCC Rules. These limits are designed to provide reasonable protection against harmful interference in a residential installation. This equipment generates, uses and can radiate radio frequency energy and, if not installed and used in accordance with the instruction, may cause harmful interference to radio communications. However, there is no guarantee that interference will not occur in a particular installation. If this equipment does cause harmful interference to radio or television reception, which can be determined by turning the equipment off and on, the user is encouraged to try to correct the interference by one or more of the following measures:

- ▶ Reorient or relocate the receiving antenna.
- ▶ Increase the separation between the equipment and receiver.
- ▶ Connect the equipment into an outlet on a circuit different from that to which the receiver is connected.
- ▶ Consult the dealer or an experienced radio/TV technician for help.

FCC Caution

- ▶ Any changes or modifications not expressly approved by the party responsible for compliance could void the user's authority to operate this equipment.
- ▶ This transmitter must not be co-located or operating in conjunction with any other antenna or transmitter.



Note

1. An unshielded-type power cord is required in order to meet FCC emission limits and also to prevent interference to the nearby radio and television reception. It is essential that only the supplied power cord be used.
2. Use only shielded cables to connect I/O devices to this equipment.
3. Changes or modifications not expressly approved by the party responsible for compliance could void the user's authority to operate the equipment.



Important

1. Operations in the 5.15-5.25GHz band are restricted to indoor usage only.
2. This device meets all the other requirements specified in Part 15E, Section 15.407 of the FCC Rules.



Important

IEC 61000-4-5: As stated above, surge testing is not required for the console if it is used under the following conditions,

- (1) Short cables only (<3m, temporary connection).
- (2) Indoor use only with no outdoor cable exposure.
- (3) Manufacturer specifies console is for service/maintenance only.

Safety Guidelines

Follow these guidelines to ensure general safety:

- ▶ Keep the chassis area clear and dust-free during and after installation.
- ▶ Do not wear loose clothing or jewelry that could get caught in the chassis. Fasten your tie or scarf and roll up your sleeves.
- ▶ Wear safety glasses if you are working under any conditions that might be hazardous to your eyes.
- ▶ Do not perform any action that creates a potential hazard to people or makes the equipment unsafe.
- ▶ Disconnect all power by turning off the power and unplugging the power cord before installing or removing a chassis or working near power supplies
- ▶ Do not work alone if potentially hazardous conditions exist.
- ▶ Never assume that power is disconnected from a circuit; always check the circuit.

Consignes de sécurité

Suivez ces consignes pour assurer la sécurité générale :

- ▶ Laissez la zone du châssis propre et sans poussière pendant et après l'installation.
- ▶ Ne portez pas de vêtements amples ou de bijoux qui pourraient être pris dans le châssis. Attachez votre cravate ou écharpe et remontez vos manches.
- ▶ Portez des lunettes de sécurité pour protéger vos yeux.
- ▶ N'effectuez aucune action qui pourrait créer un danger pour d'autres ou rendre l'équipement dangereux.
- ▶ Coupez complètement l'alimentation en éteignant l'alimentation et en débranchant le cordon d'alimentation avant d'installer ou de retirer un châssis ou de travailler à proximité de sources d'alimentation.
- ▶ Ne travaillez pas seul si des conditions dangereuses sont présentes.
- ▶ Ne considérez jamais que l'alimentation est coupée d'un circuit, vérifiez toujours le circuit. Cet appareil génère, utilise et émet une énergie radiofréquence et, s'il n'est pas installé et utilisé conformément aux instructions des fournisseurs de composants sans fil, il risque de provoquer des interférences dans les communications radio.

Lithium Battery Caution

- ▶ There is risk of explosion if the battery is replaced by an incorrect type.
- ▶ Dispose of used batteries according to the instructions.
- ▶ Installation should be conducted only by a trained electrician or only by an electrically trained person who knows all installation procedures and device specifications which are to be applied.
- ▶ Do not carry the handle of power supplies when moving to another place.
- ▶ Please conform to your local laws and regulations regarding safe disposal of lithium battery.
- ▶ Disposal of a battery into fire or a hot oven, or mechanically crushing or cutting of a battery can result in an explosion.
- ▶ Leaving a battery in an extremely high temperature environment can result in an explosion or the leakage of flammable liquid or gas.
- ▶ A battery subjected to extremely low air pressure may result in an explosion or the leakage of flammable liquid or gas.

Avertissement concernant la pile au lithium

- ▶ Risque d'explosion si la pile est remplacée par une autre d'un mauvais type.
- ▶ Jetez les piles usagées conformément aux instructions.
- ▶ L'installation doit être effectuée par un électricien formé ou une personne formée à l'électricité connaissant toutes les spécifications d'installation et d'appareil du produit.
- ▶ Ne transportez pas l'unité en la tenant par le câble d'alimentation lorsque vous déplacez l'appareil.

Operating Safety

- ▶ Electrical equipment generates heat. Ambient air temperature may not be adequate to cool equipment to acceptable operating temperatures without adequate circulation. Be sure that the room in which you choose to operate your system has adequate air circulation.
- ▶ Ensure that the chassis cover is secure. The chassis design allows cooling air to circulate effectively. An open chassis permits air leaks, which may interrupt and redirect the flow of cooling air from internal components.
- ▶ Electrostatic discharge (ESD) can damage equipment and impair electrical circuitry. ESD damage occurs when electronic components are improperly handled and can result in complete or intermittent failures. Be sure to follow ESD-prevention procedures when removing and replacing components to avoid these problems.
- ▶ Wear an ESD-preventive wrist strap, ensuring that it makes good skin contact. If no wrist strap is available, ground yourself by touching the metal part of the chassis.
- ▶ Periodically check the resistance value of the antistatic strap, which should be between 1 and 10 megohms (Mohms).

Sécurité de fonctionnement

- ▶ L'équipement électrique génère de la chaleur. La température ambiante peut ne pas être adéquate pour refroidir l'équipement à une température de fonctionnement acceptable sans circulation adaptée. Vérifiez que votre site propose une circulation d'air adéquate.
- ▶ Vérifiez que le couvercle du châssis est bien fixé. La conception du châssis permet à l'air de refroidissement de bien circuler. Un châssis ouvert laisse l'air s'échapper, ce qui peut interrompre et rediriger le flux d'air frais destiné aux composants internes.
- ▶ Les décharges électrostatiques (ESD) peuvent endommager l'équipement et gêner les circuits électriques. Des dégâts d'ESD surviennent lorsque des composants électroniques sont mal manipulés et peuvent causer des pannes totales ou intermittentes. Suivez les procédures de prévention d'ESD lors du retrait et du remplacement de composants.
- ▶ Portez un bracelet anti-ESD et veillez à ce qu'il soit bien au contact de la peau. Si aucun bracelet n'est disponible, reliez votre corps à la terre en touchant la partie métallique du châssis.
- ▶ Vérifiez régulièrement la valeur de résistance du bracelet antistatique, qui doit être comprise entre 1 et 10 mégohms (Mohms).

Mounting Installation Precautions

The following should be put into consideration for rack-mount or similar mounting installations:

- ▶ Do not install and/or operate this unit in any place that flammable objects are stored or used in.
- ▶ The installation of this product must be performed by trained specialists; otherwise, a non-specialist might create the risk of the system's falling to the ground or other damages.
- ▶ Lanner Electronics Inc. shall not be held liable for any losses resulting from insufficient strength for supporting the system or use of inappropriate installation components.
- ▶ Elevated Operating Ambient - If installed in a closed or multi-unit rack assembly, the operating ambient temperature of the rack environment may be greater than room ambient. Therefore, consideration should be given to installing the equipment in an environment compatible with the maximum ambient temperature (T_{ma}) specified by the manufacturer.
- ▶ Reduced Air Flow - Installation of the equipment in a rack should be such that the amount of airflow required for safe operation of the equipment is not compromised.
- ▶ Mechanical Loading - Mounting of the equipment in the rack should be such that a hazardous condition is not achieved due to uneven mechanical loading.
- ▶ Circuit Overloading - Consideration should be given to the connection of the equipment to the supply circuit and the effect that overloading of the circuits might have on overcurrent protection and supply wiring. Appropriate consideration of equipment nameplate ratings should be used when addressing this concern.
- ▶ Reliable Grounding - Reliable grounding of rack mounted equipment should be maintained. Particular attention should be given to supply connections other than direct connections to the branch circuit (e.g. use of power strips).
- ▶ Suitable for installation in Information Technology Rooms in accordance with Article 645 of the National Electrical Code and NFPA 75.
- ▶ The machine can only be used in a restricted access location and must be installed by a skilled person.

Warning

- ▶ Class I Equipment. This equipment must be earthed. The power plug must be connected to a properly wired earth ground socket outlet. An improperly wired socket outlet could place hazardous voltages on accessible metal parts.
- ▶ Product shall be used with Class 1 laser device modules.

Avertissement

- ▶ Équipement de classe I. Ce matériel doit être relié à la terre. La fiche d'alimentation doit être raccordée à une prise de terre correctement câblée. Une prise de courant mal câblée pourrait induire des tensions dangereuses sur des parties métalliques accessibles.
- ▶ Le produit doit être utilisé avec des modules de dispositifs laser de classe 1.

Electrical Safety Instructions

Before turning on the device, ground the grounding cable of the equipment. Proper grounding (grounding) is very important to protect the equipment against the harmful effects of external noise and to reduce the risk of electrocution in the event of a lightning strike. To uninstall the equipment, disconnect the ground wire after turning off the power. A ground wire (green-and-yellow) is required and the part connecting the conductor must be greater than 4 mm² or 10 AWG.

Consignes de sécurité électrique

- ▶ Avant d'allumer l'appareil, reliez le câble de mise à la terre de l'équipement à la terre.
- ▶ Une bonne mise à la terre (connexion à la terre) est très importante pour protéger l'équipement contre les effets néfastes du bruit externe et réduire les risques d'électrocution en cas de foudre.
- ▶ Pour désinstaller l'équipement, débranchez le câble de mise à la terre après avoir éteint l'appareil.
- ▶ Un câble de mise à la terre est requis et la zone reliant les sections du conducteur doit faire plus de 4 mm² ou 10 AWG.

Grounding Procedure for This Device

- ▶ Connect the grounding cable to the ground.
- ▶ The protection device for the DC power source must provide 40A current.
- ▶ This protection device must be connected to the power source before DC power.

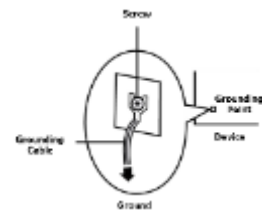

Procédure de mise à la terre l'équipement

- ▶ Branchez le câble de mise à la terre à la terre.
- ▶ L'appareil de protection pour la source d'alimentation CC doit fournir 40A de courant.
- ▶ Cet appareil de protection doit être branché à la source d'alimentation avant l'alimentation CC.

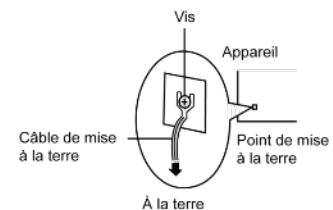

CAUTION: TO DISCONNECT POWER, REMOVE ALL POWER CORDS FROM UNIT.

注意：要断开电源，请将所有电源线从本机上拔下。

注意：要斷開電源，請將所有電源線從本機上拔下。

WARNUNG: Wenn Sie das Gerät zwecks Wartungsarbeiten vom Netz trennen müssen, müssen Sie beide Netzteile abnehmen.

ATTENTION: DÉBRANCHER TOUS LES CORDONS D'ALIMENTATION POUR DÉCONNECTER L'UNITÉ DU SECTEUR.



Note

The product is intended to be supplied by UL listed DC power source with rated 36-46Vdc; 46-72Vdc, 40A minimum, maximum operating ambient is 40-degree C minimum and the altitude of operation = 5000m minimum. (The power cable should be used at 8 AWG minimum.)

Table of Contents

Chapter 1: Product Overview 10

Optional Accessories	10
Ordering Information	10
System Specifications	11
Front Panel	13
Rear Panel.....	14
Motherboard Information.....	15

Chapter 2: Hardware Setup.....25

Opening the Chassis	25
Installing the CPU	26
Installing the System Memory.....	32
Installing TPM Module (Optional)	35
Installing the M.2 SSD memory card (Optional).....	36
Installing the Disk Drive(s).....	37
Installing the LCM Module (Optional).....	39
Installing the NIC Modules	41
Installing the IPMI card.....	43
Replacing the Cooling Fans.....	44
Mounting the System	46

Chapter 3: BIOS Setup50

Main.....	51
Advanced	52
Platform Configuration.....	73
Socket Configuration	79
Server Mgmt.....	93

Security.....98
Boot Menu.....101
Save and Exit Menu102

Appendix A: LED indicator explanations104

Appendix B: Terms and Conditions105

Warranty Policy105

CHAPTER 1: PRODUCT OVERVIEW

NCA-5530 is a high performance 1U rackmount network security system utilizing the cutting-edge capabilities of the Intel Whitley platform and with its I/O versatility and scalability, it is the perfect hardware platform for enhancing network traffic management and virtualized network security. The appliance aims to maximize packet processing efficiency for virtual network functions, cryptography acceleration for deep packet inspection and next-generation firewall and UTM/IPS/IDS applications. NCA-5530 supports difference SKUs up to 4x NCS2 modules or 2x N2S module.

Package Content

Your package contains the following items:

- ▶ 1x NCA-5530 Network Security Platform
- ▶ 1x Processor Carrier, 1x CPU Heatsink
- ▶ 8x HDD screws
- ▶ 1x RJ45 Console cable, 1x RJ45 LAN Cable (Grey), 2x Power cable
- ▶ 1x Short Ear Rack mount kit with screws

Optional Accessories

Model No.	Description
NCS2-LCM6210A	LCM Module for NCS2 (By ODM/OEM)
IAC-TPM04A	TPM Module (SPI)
Power Module	550W AC Redundant Power Module
PCIe Cable	Gen4 Slim SAS to PCIe Cable, for extend front NIC (requires installation by manufacturer)
Slide Rail Kit	Slide Kit for 1U chassis (438mm wide)
IAC-AST2500E	IPMI Card
Fan Kit	Hot-swap Fan kit

Ordering Information

SKU No.	Main Features
NCA-5530A	Ice Lake-SP (205W), PCH C629A, 4x NIC module slots, 1x GbE RJ45 MGMT share with LOM with 550W 1+1 redundancy PSU, 5x Hot-swappable Cooling Fans
NCA-5530B	Ice Lake-SP (205W), PCH C621A, 4x NIC module slots, 1x GbE RJ45 MGMT share with LOM with 550W 1+1 redundancy PSU, 5x Hot-swappable Cooling Fans
NCA-5530C	Ice Lake-SP (165W), PCH C621A, 2x NIC module slots, 1x GbE RJ45 MGMT share with LOM with 550W 1+1 redundancy PSU, 4x Hot-swappable Cooling Fans

System Specifications

Form Factor		1U 19" Rackmount
Platform	Processor Options	Intel® Xeon® Processor Scalable Family (Ice Lake SP)
	CPU Socket	1x LGA4189
	Chipset	Intel® C629A / C621A
	Security Acceleration	QuickAssist Technology (NCA-5530A only)
BIOS		AMI SPI Flash BIOS
System Memory	Technology	DDR4 2133/2400/2666/2933/3200MHz RDIMM / LRDIMM
	Max. Capacity	512GB
	Socket	8x 288-pin DIMM Socket (8 channels; 1DPC)
Networking	Ethernet Ports	1x GbE RJ45 w/LED MGT by Intel® i210 (support PXE; default Disable)
	Bypass	N/A
	NIC Module Slot	NCA-5530A & NCA-5530B: 4x NIC module slots NCA-5530C: 2x NIC module slots
LOM	I/O Interface	Yes, share with MGT RJ-45 port (LOM function only when IAC-AST2500E install)
	OPMA slot	Socket type
I/O Interface	Reset Button	1x Reset Button (Default software reset control by GPIO)
	LED	Power/Status/Storage , refer to Appendix A
	Power Button	1x ATX Power Switch
	Console	1x RJ45 Console
	USB	2x USB 3.0
	LCD Module	N/A (Default); LCM (Optional)
	Display	N/A
Storage	HDD/SSD Support	2x 2.5" Internal HDD/SSD
	Onboard Slots	1x M.2-2280 M-Key (SATA III)
Expansion	PCIe	1x PCIe x8 Gen4 for FH/HL Size Card (By project)
Miscellaneous	Watchdog	Yes
	Internal RTC with Li Battery	Yes
	TPM	N/A (Default); Yes (Optional)
Cooling	Processor	Passive CPU Heatsink
	System	NCA-5530A & NCA-5530B: 5x Hot-swappable Cooling Fans NCA-5530C: 4x Hot-swappable Cooling Fans
Environmental Parameters	Temperature	0~40°C Operating -20~70°C Non-Operating
	Humidity (RH)	5~90% Operating 5~95% Non-Operating
System Dimensions	Size (WxDxH)	438 x 610 x 44 mm
	Weight	10.5kg

Package Dimensions	Size (WxDxH)	739 x 215 x 582 mm
	Weight	18.5kg
Power	Type/Watts	550W AC 1+1 Redundant PSU
	Input	AC PSU: 100-240V~, 8-4A, 50-60Hz; 100-127V~7.5A; 200-240V~3.9A, 47-63Hz DC PSU: 36V-46Vdc 35A Max; 46-72Vdc 40A Max (Optional)
Approvals and Compliance		RoHS Directive (EU) 2015/863, CE/FCC Class A, UL, VCCI, UKCA

Front Panel

NCA-5530A / NCA-5530B



NCA-5530C

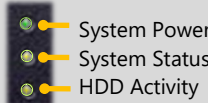

No.	Description	
F1	Reset button	1x Reset Button
F2	LED Indicators	 <ul style="list-style-type: none"> ● System Power ● System Status ● HDD Activity
F3	USB Ports	2x USB 3.0
F4	RJ45 Port	1x RJ45 port
F5	Console Port	1x Console port
F6	NIC Module Slot	4x or 2x NCS2 Slim Type Module (By SKU); or 1x or 2x N2S NIC Module (By Project)

Rear Panel

NCA-5530A / NCA-5530B

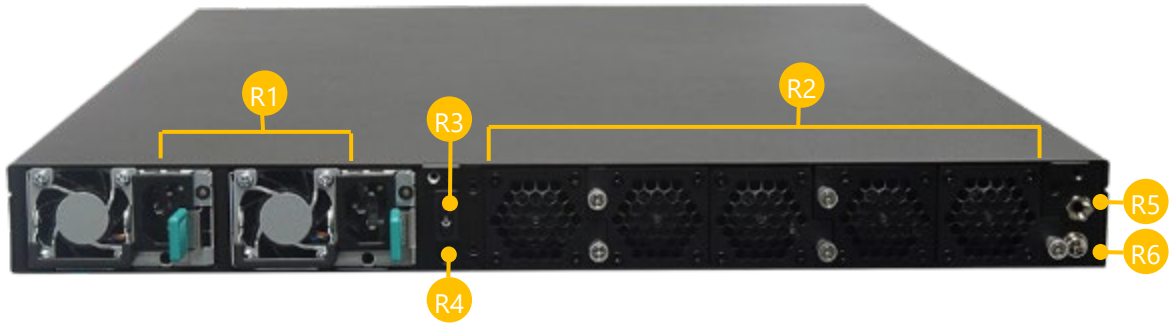

NCA-5530C

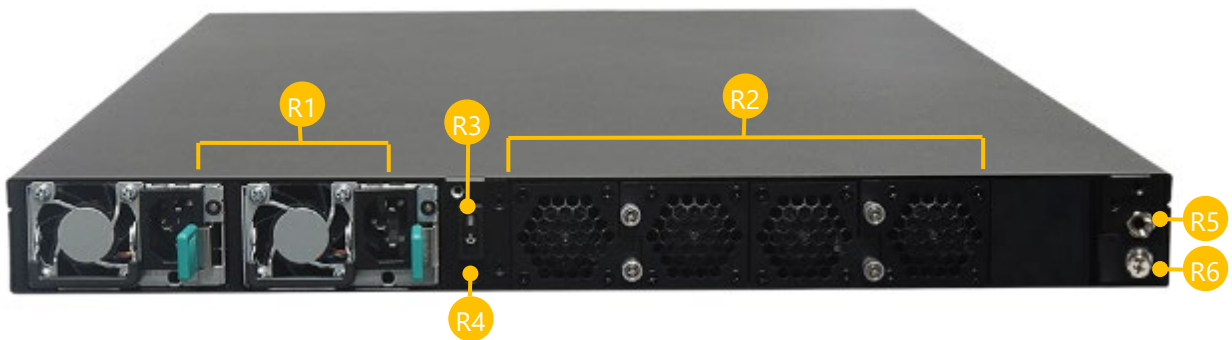

No.	Description	
R1	Power Supply	2x 550W AC 1+1 Redundant CRPS Power Supply
R2	Fans	5x or 4x Hot-swappable Cooling Fans (By SKU)
R3	Power Switch	1x Power Switch I/O Button
R4	Alarm Reset	1x Alarm Reset Button
R5	ESD Jack	1x ESD screw hole
R6	Ground Hole	1x Ground screw hole

Motherboard Information

Block Diagram

The block diagram indicates how data flows among components on the motherboard.

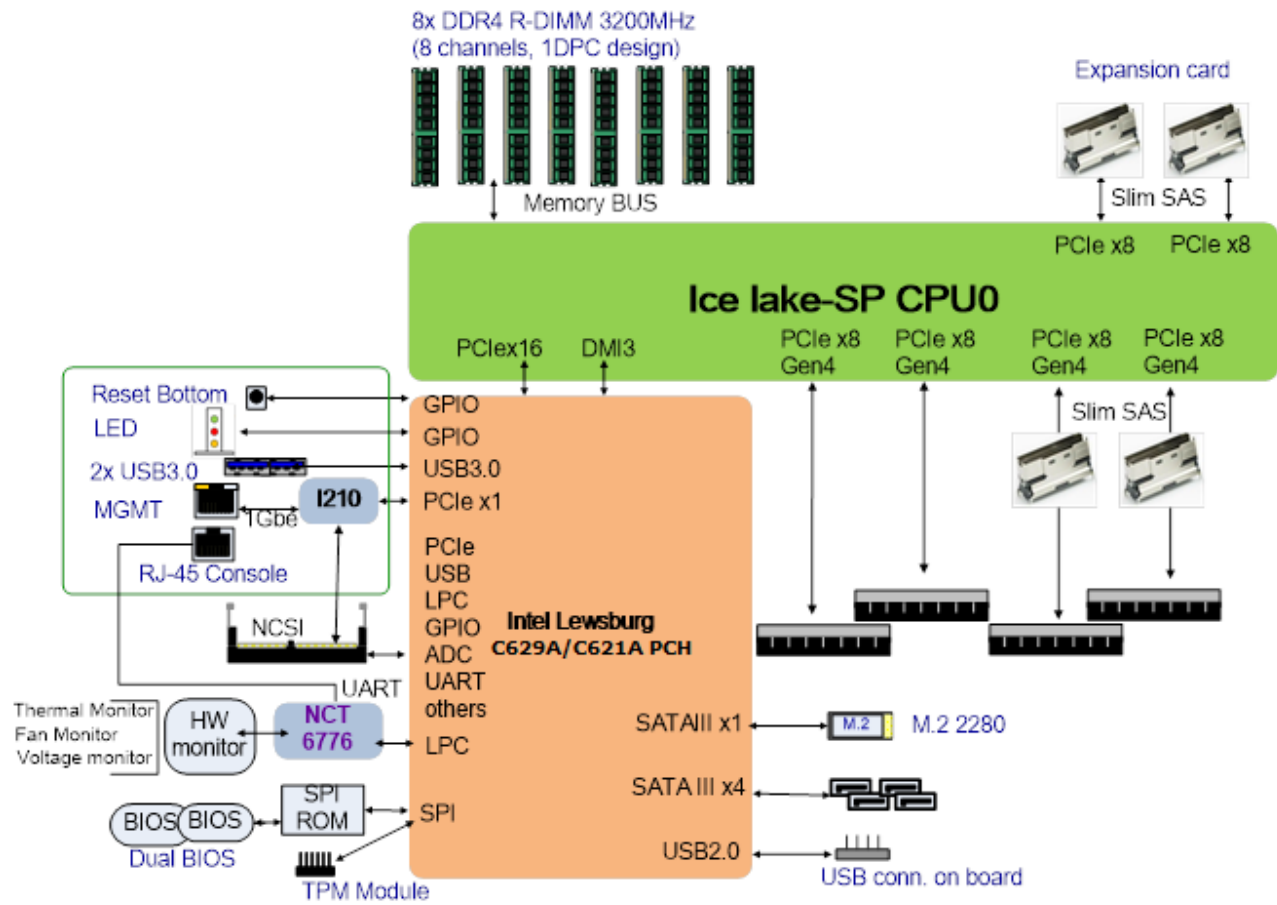

Motherboard Layout

The motherboard layout shows the connectors and jumpers on the board. Refer to the following picture as a reference of the pin assignments and the internal connectors.

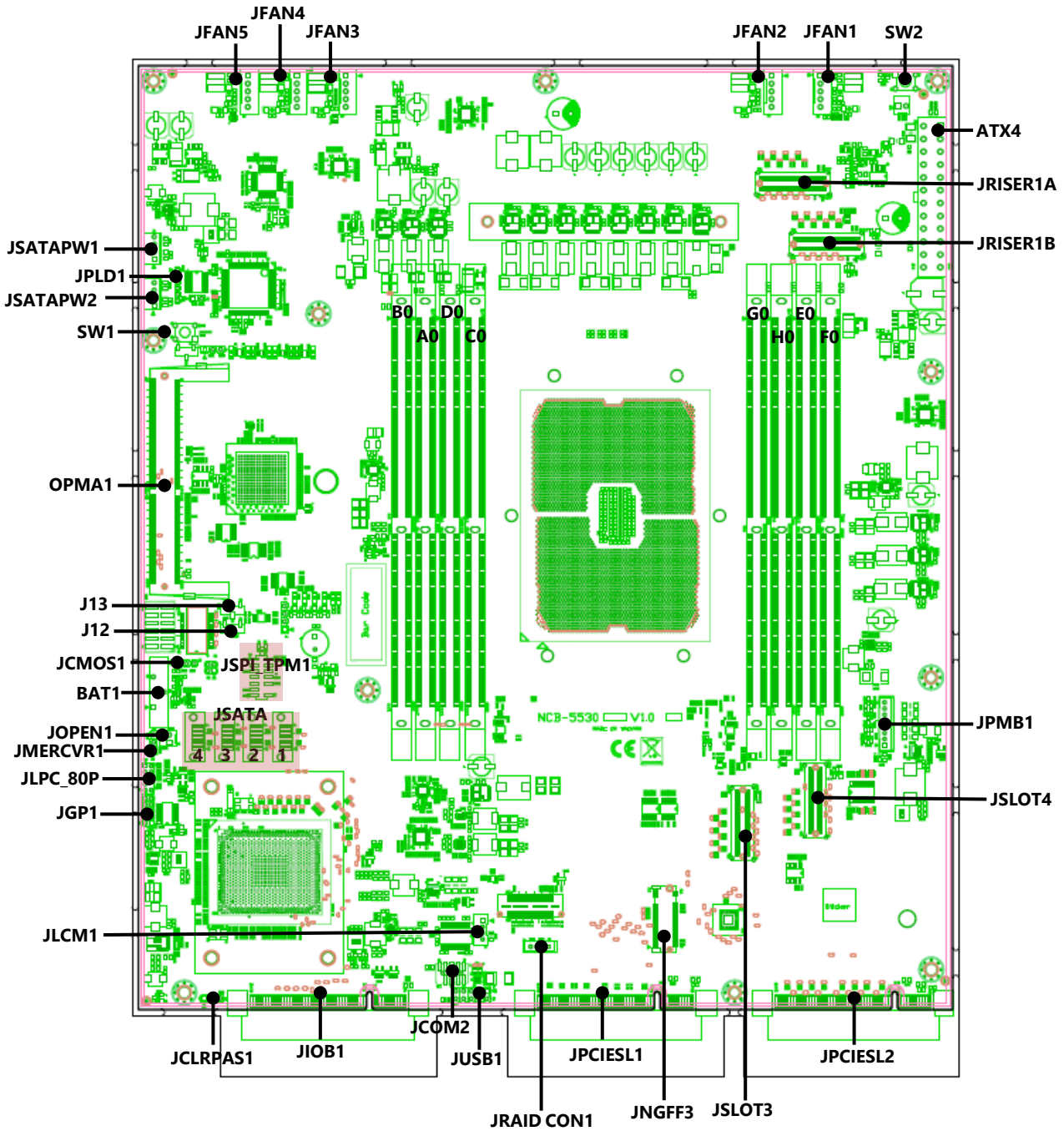

Internal Jumpers and Connectors

The pin headers on the motherboard are often associated with important functions. With the shunt (Jumper) pushed down on the designated pins (the pin numbers are printed on the circuit board, surrounding the pin header), certain feature can be enabled or disabled. While changing the jumpers, make sure your system is turned off.

JUSB1: USB2.0

Pin No.	Description	Pin No.	Description
1	+P5V_USB2	2	+P5V_USB2
3	USB20_L_N3	4	USB20_L_N4
5	USB20_L_P3	6	USB20_L_P4
7	USBGND1	8	USBGND1
9	USBGND1	10	USBGND1

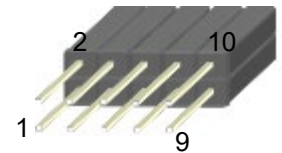

PLD1

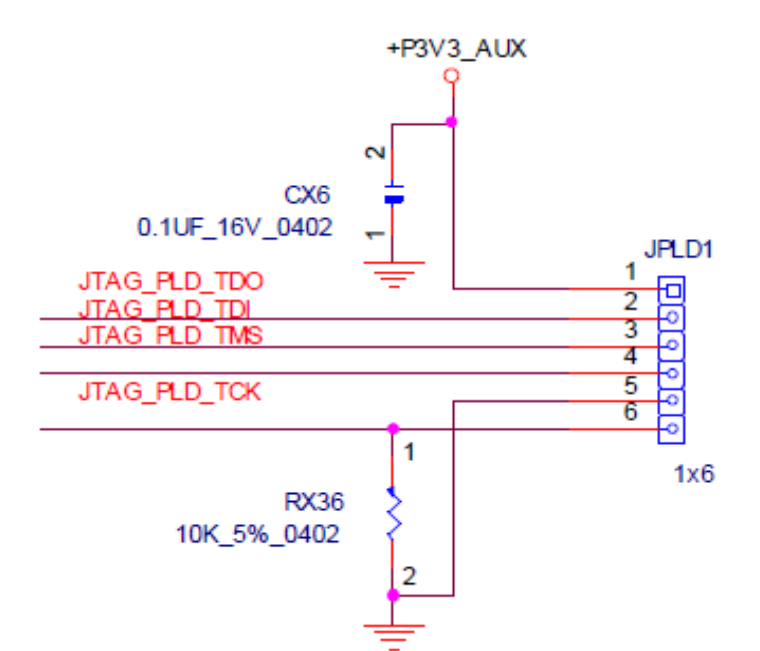

JGP1: EXT GPIO header

Pin No.	Description	Pin No.	Description
1	GPO_B_1	2	GPI_B_1
3	GPO_B_2	4	GPI_B_2
5	GPO_B_3	6	GPI_B_3
7	GPO_B_4	8	GPI_B_4
9	GND	10	GND

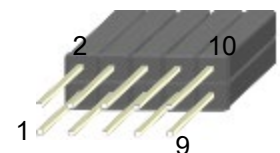

JLPC_80P

Pin No.	Description	Pin No.	Description
1	LPC_80PORT_CLK	2	LPC_80PORT_LAD1
3	LPC_80PORT_RST	4	LPC_80PORT_LAD0
5	LPC_80PORT_LFRAME	6	+P3V3
7	LPC_80PORT_LAD3	8	NA
9	LPC_80PORT_LAD2	10	GND

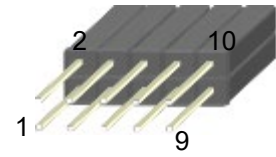

JSPI_TPM1:

Pin No.	Description	Pin No.	Description
1	SPI_HD1#	2	SPI_CS1#
3	SPI_CS0#	4	+P3V3_SPI_PCH_AUX
5	SPI_MISO_TPM	6	HEADER_SPI_PCH_IO3
7		8	SPI_CLK_TPM
9	GND	10	SPI_MOSI_TPM
11	IRQ_TPM_SPI#_R	12	
13	SPI_TPM_CS0#	14	RST_PLTRST_PLD_B_N

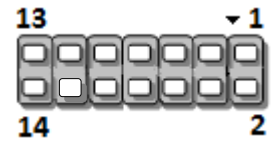

JSATAPW1 & 2:

Pin No.	Description
1	+P12V
2	GND
3	GND
4	+P5V



JRAID_CON1:

Pin No.	Description
1	GND
2	+P3V3_AUX
3	GND
4	FM_PCH_STORAGE_KEY_R



JLCM1:

Pin No.	Description
1	BMC_LCM_TX
2	BMC_LCM_RX
3	GND
4	+P5V



JPWR1:

Pin No.	Description
1	PWRON#
2	GND

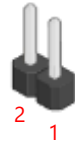

JOPEN1:

Pin No.	Description
1	FM_INTRUDER#
2	GND

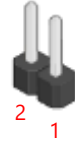

JFAN1~5: FAN Connector

Pin No.	Description
1	Ground
2	+P12V
3	FAN_TECH_IN Sense 2
4	FAN_TECH_IN Sense 1
5	FAN_PWM_OUT



SW1: Front Panel RST Button

SW2: Power ON Button

JSATA1~4: SATA

Pin No.	Description
1	GND
2	TX_P
3	TX_N
4	GND
5	RX_N
6	RX_P
7	GND

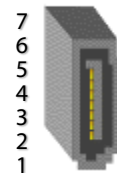

POWER CONNECTOR

ATX4: 24 Pin Power Connector

Pin No.	Description	Pin No.	Description
2	12VSB	1	GND
4	5V	3	GND
6	12V	5	GND
8	12V	7	GND
10	12V	9	GND
12	12V	11	GND
14	12V	13	GND
16	12V	15	GND
18	12V	17	GND
20	12V	19	GND
22	3V	21	GND
24	3V	23	GND

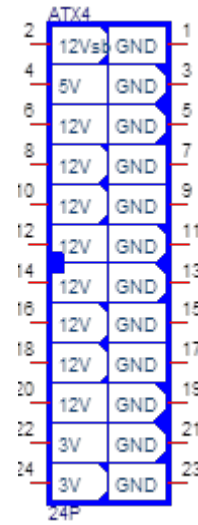

JNGFF3



Jumper Setting

To short the designated pins, push the jumper down on them so that they become **SHORT**. To make the pins setting **OPEN**, simply remove the jumper cap.

2-pin Header		3-pin Header		4-pin Header	
Open	Short	Open	(1-2) Jumped	Open	(1-2) Jumped

JFOR_PWRON1 (1-2)

1-2 Normal Operation (Default)

2-3 Force PFR CPLD Update

Pin No.	Description
1	
2	FM_FORCE_PWRON_LVC3
3	GND



JCLRPAS1 (1-2)

1-2 Normal (Default)

2-3 Password Clear

Pin No.	Description
1	
2	FM_PW_CLEAR#
3	GND



JMERCVR1 (1-2)

1-2 Normal

2-3 ME Force Update

Pin No.	Description
1	
2	FM_ME_RCVR_N
3	GND



JCMOS1 (1-2)

1-2 Normal

2-3 Clear CMOS

Pin No.	Description
1	+VRTC
2	PCH_RTCRST#
3	PD_PCH_RTCRST#



JPMB1: PMBUS

Pin No.	Description	Pin No.	Description
1	P3V3_SB	2	
3	ATX_PSON#	4	GND
5	ATXPWGD	6	PMBUS_CLK
7	PMBUS_DAT	8	PMBUS_ALERT#



JJDUAL1: Chip Select

Pin No.	Description	Pin No.	Description
1	SPI_CS0#	2	SPI_PCH_MUXED_CS0_N
3	SPI_PCH_MUXED_CS1_N	4	SPI_CS1#

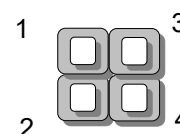

J13 (1-2)1

1-2 Force Boot Up from BIOS (Default)

2-3 Force Boot Up from BIOS2

Pin No.	Description
1	+P3V3_AUX
2	BIOS_BOOT_SEL
3	GND



J12 (1-2)1

1-2 Enable dual BIOS (Default)

2-3 Disable dual BIOS

Pin No.	Description
1	+P3V3_AUX
2	DUAL_BIOS_DIS
3	GND



JCOM2

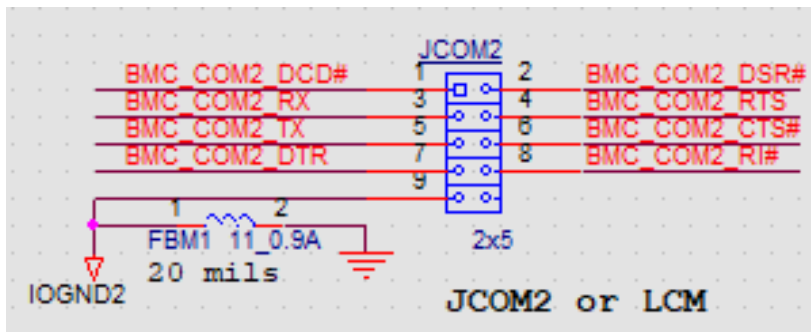

Power Board Layout

The power board layout shows the connectors and jumpers on the board. Refer to the following picture as a reference of the pin assignments and the internal connectors.

JATX1-4, 24 & 25: 4-pin Power Connector

Pin No.	Description	Pin No.	Description
1	GND	2	GND
3	P3V3	4	P12V

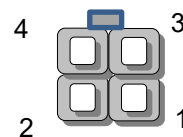

JATXP12V: 4-pin Power Connector

Pin No.	Description	Pin No.	Description
1	GND	2	P12V
3	GND	4	P12V

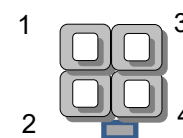

JATX23: 8-pin Power Connector

Pin No.	Description	Pin No.	Description
1	GND	2	GND
3	GND	4	GND
5	P12V	6	P12V
7	P12V	8	P12V

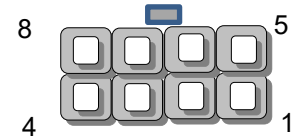

J2: MCU Connector

Pin No.	Description	Pin No.	Description
1	P1V8LC	2	TDO_4032
3	TDI_4032	4	NA
5	NA	6	TMS_4032
7	GND	8	TCK_4032



CONN1: 2-pin Power Alert

Pin No.	Description	Pin No.	Description
1	Alert	2	GND

JPMB1: PMBUS

Pin No.	Description	Pin No.	Description
1	P3V3_SB	2	
3	ATX_PSON#	4	GND
5	ATXPWGD	6	PMBUS_CLK
7	PMBUS_DAT	8	PMBUS_ALERT#



JATXP5V: 4-pin Power Connector

Pin No.	Description	Pin No.	Description
1	GND	2	P5V
3	GND	4	P5V

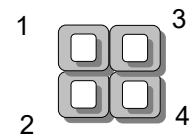

DC1-3: 4-pin Power Connector

Pin No.	Description	Pin No.	Description
1	P12V	2	P5V
3	P3V3	4	GND



ATX4: 24-pin Power Connector

Pin No.	Description	Pin No.	Description
2	12Vsb	1	GND
4	5V	3	GND
6	12V	5	GND
8	12V	7	GND
10	12V	9	GND
12	12V	11	GND
14	12V	13	GND
16	12V	15	GND
18	12V	17	GND
20	12V	19	GND
22	3V	21	GND
24	3V	23	GND

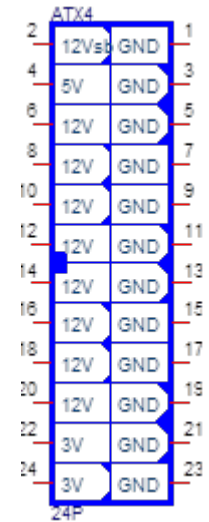

PWRJ1 & 2: PMBUS Power Connector

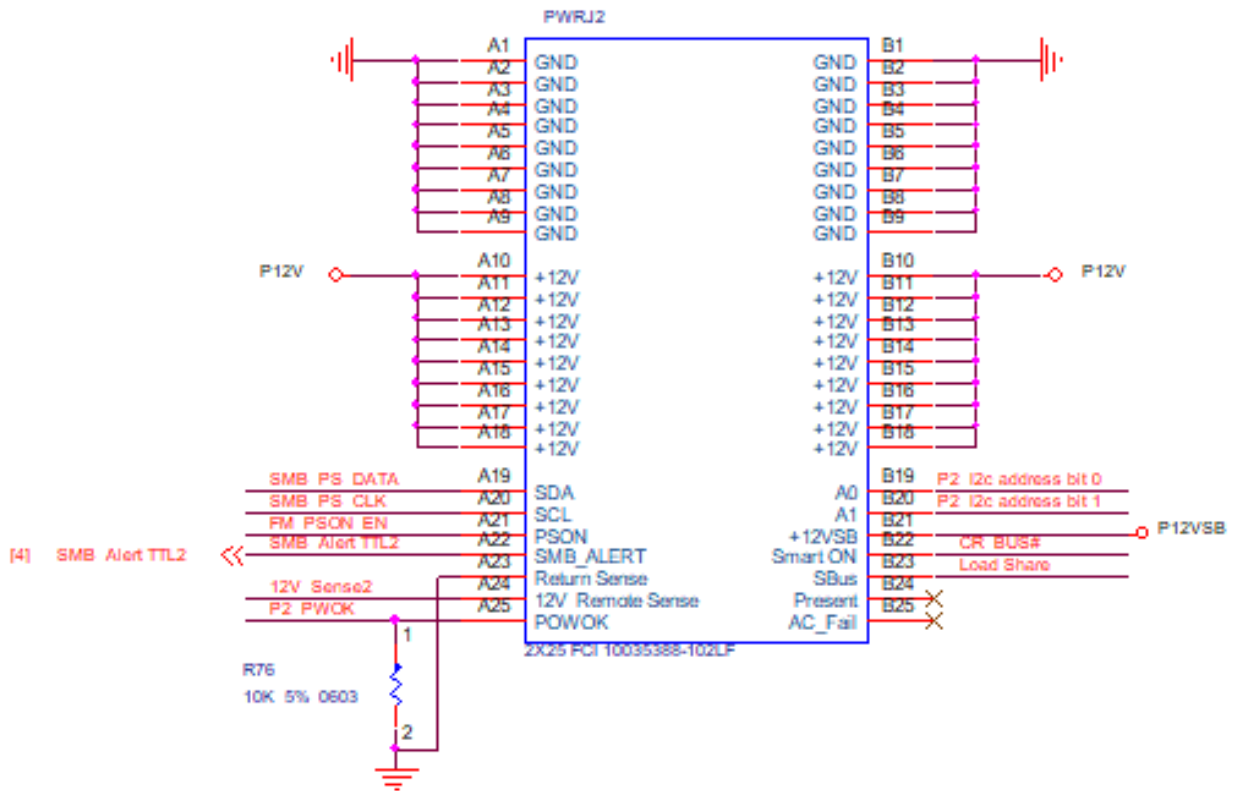

CHAPTER 2: HARDWARE SETUP

To reduce the risk of personal injury, electric shock, or damage to the system, please remove all power connections to shut down the device completely and wear ESD protection gloves when handling the installation steps.

Opening the Chassis

1. Loosen the two (2) thumb screws on the rear panel.



2. Gently slide the top cover backward a bit.



3. Lift the cover up to remove it.





Installing the CPU

Please note that the system delivered to you includes the heatsink and processor. This processor comes with a rather sophisticated design, therefore, the assembly of which must be handled with exclusive tools and extreme care by professionals. Please read through the instructions in this section and refer to the [official tutorial](#) released by Intel® to make sure you have acquired the necessary knowledge and comply with the requirements.

Installing the processor onto the motherboard involves two stages:

1. Mount the processor onto the heat sink to make a PHM (Processor + Heat Sink Module)
2. Install the PHM onto the motherboard.

Tools Required



Tool	Description	
Torque screwdriver (T-30 Torx Bit®)	Set to 8in/lb for tightening the nuts which fasten the PHM on the bolster plate.	
ESD Protection (ESD gloves, ESD-safe work surface, etc.)	During the entire assembly process, at least wear a pair of ESD gloves to avoid damaging or contaminating the electronic parts while enhancing your own safety.	

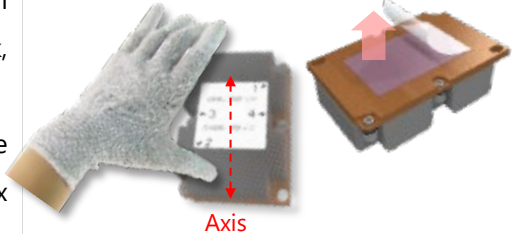

Note: The images of tools shown in this document are merely for reference; the actual tools you use might differ.

Parts Explanation:

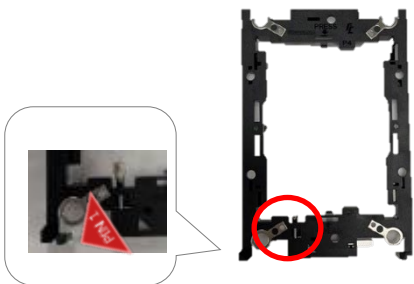
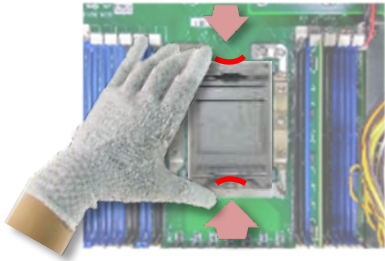
Item	Description	
Processor	Please avoid touching the gold fingers or package lands of the processor even if you are wearing ESD gloves.	
Heat Sink	If a TIM (Thermal Interface Material) protective film is already attached to the base of the heat sink, remove it before you mount the processor on it. When holding the heatsink, please grip it along the axis of its fins with your thumb and your index finger.	

<p>Processor Carrier</p>	<p>This is packed along with the processor. Before performing any assembly involving this part, please locate PIN1 on one of the corners, an important indicator used to align this carrier with the processor and the bolster plate correctly.</p>	 <p>The image shows a black metal processor carrier. A red circle highlights a specific corner. An inset image shows a close-up of a red triangular marker with 'PIN1' written on it, pointing to the corner of the carrier.</p>
<p>Socket Cover</p>	<p>This cover is used to protect the package land surface of the processor from contamination. To remove it from the processor, grasp the holding features with your thumb and your index finger while pulling the cover off vertically.</p>	 <p>The image shows a gloved hand pulling a metal socket cover off a processor. Red arrows indicate the upward and outward direction of removal.</p>
<p>Bolster Plate</p>	<p>A robust bolster plate is used to assist in PHM alignment for installation, while effectively helping eliminate PCB bowing during compression. Please locate the Cutout on one of the four corners before starting PHM installation.</p>	 <p>The image shows a metal bolster plate mounted on top of a processor, which is seated in a socket on a green PCB.</p>

Mounting the CPU onto the Heat Sink

1. With the processor in the shipping tray, align the **PIN1** indicator on the processor carrier to the **PIN1** marking on the processor.

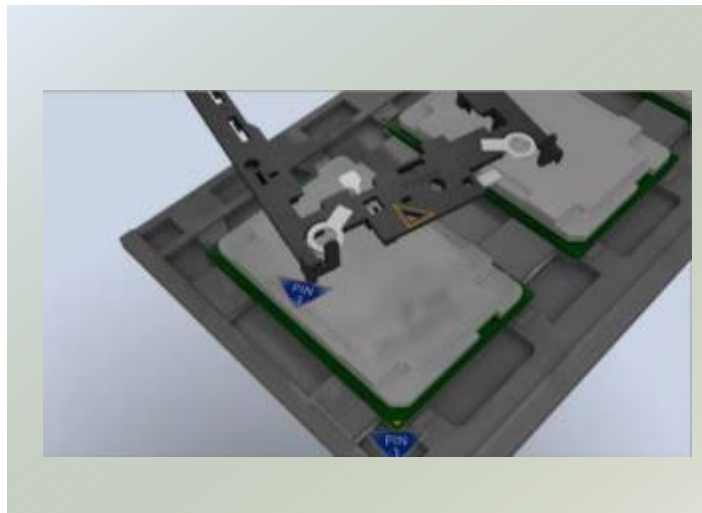

2. And line up the two keying features on the processor carrier.

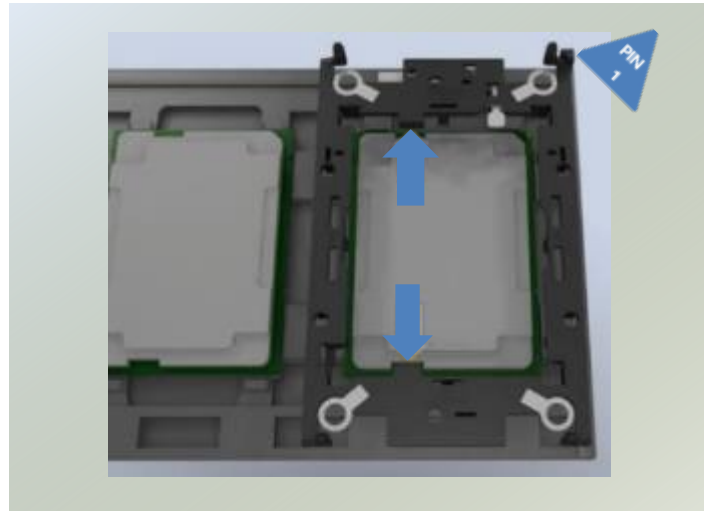

3. Gently press on the each of the press tabs at the top and bottom of the carrier to engage the locking tabs

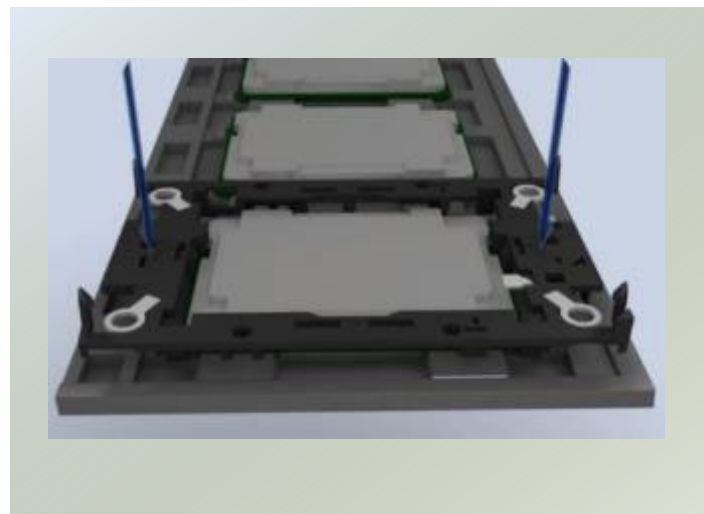

Note: During assembly, it is essential to have (1) PIN1 on the processor carrier aligned with the processor, and (2) the alignment features on the top and the bottom of the processor aligned with the corresponding carrier latches.

4. Push down on the two sides to engage the side locking tabs. Check to make sure all four locking tabs have been attached to the processor.

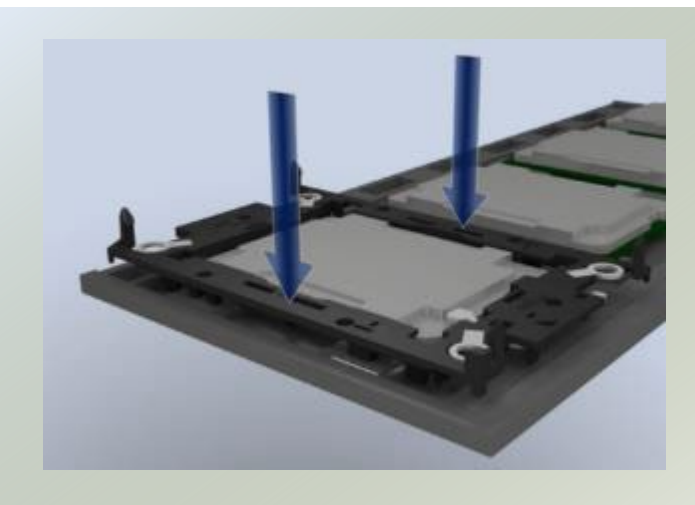

5. Align **PIN1** of the heatsink to the PIN1 indicator of the processor carrier (if there are two corner cutouts on one heat sink, either will do).

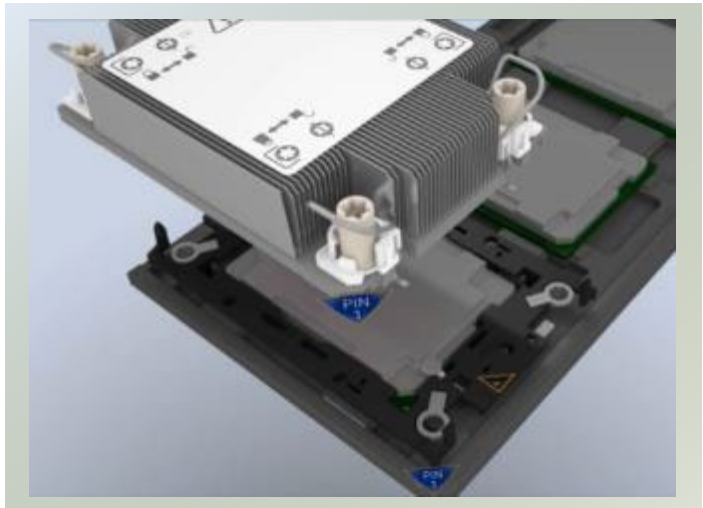

6. Lower the PIN1 end of the heatsink over the processor carrier to engage the two locking tabs near the corners. Then push the other end down to engage the locking tabs at the remaining corners. You might hear a clicking sound when the latch clicks into place. There should not be any gaps between the heatsink and the carrier.

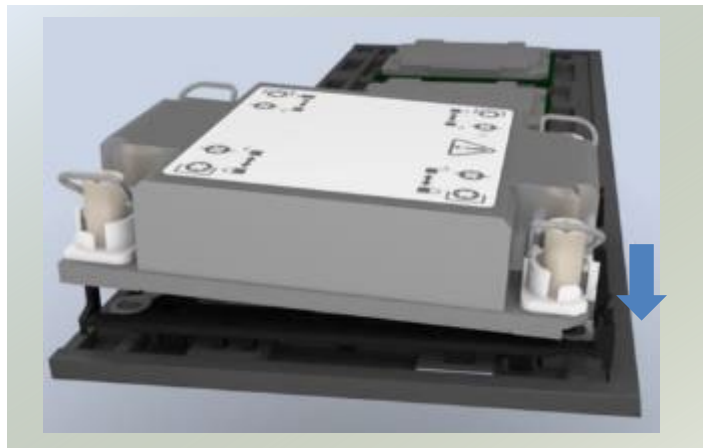

7. The PHM is now ready to be integrated into the socket.

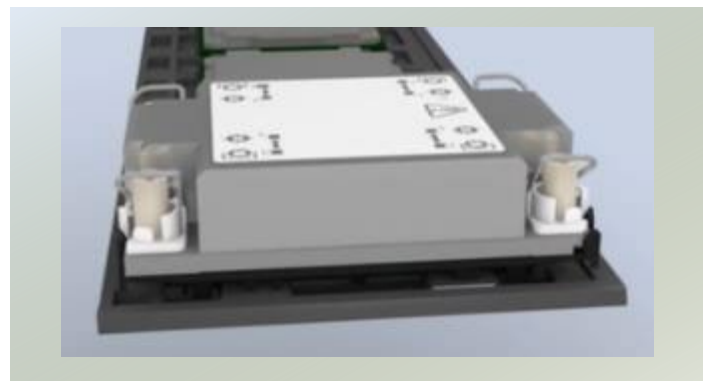

Installing the PHM onto the Motherboard

1. Remove the socket cover from the socket contacts of the motherboard by grasping the tabs on either side. Squeeze inward

Note: Inspect the surface of the socket under sufficient lighting to ensure there is no contamination or damage prior to the PHM installation.

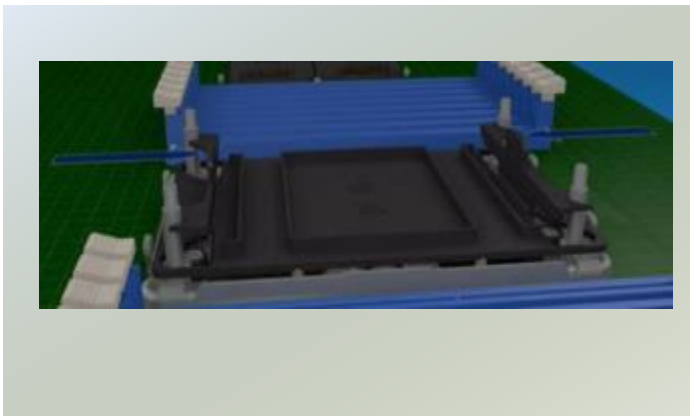

2. Set each anti-tilt wire to inward or unlocked position on the heatsink.



3. Lift up the PHM. Turn the PHM over to locate the PIN1 corner on processor carrier and processor.

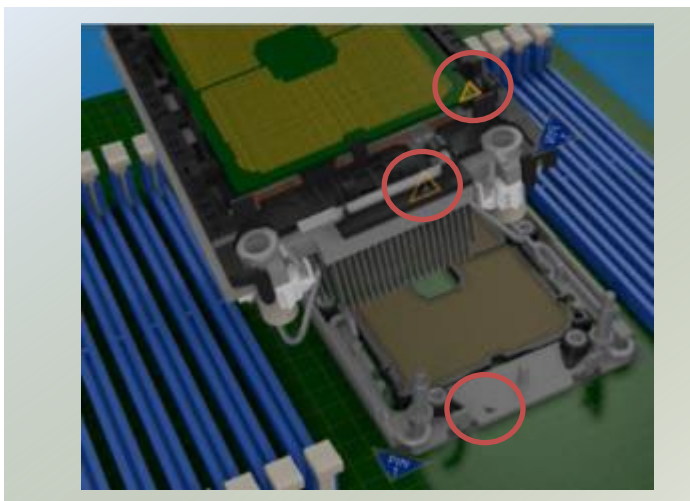

4. Then turn the PHM right side up. Line up the PIN1 corner of the PHM to the bolster plate PIN1 corner. Lower the PHM vertically down over the bolster plate studs.

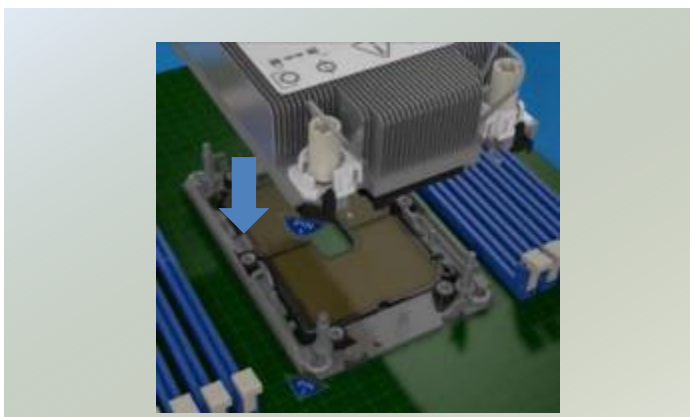

5. Move each anti-tilt wire to outward or locked position.

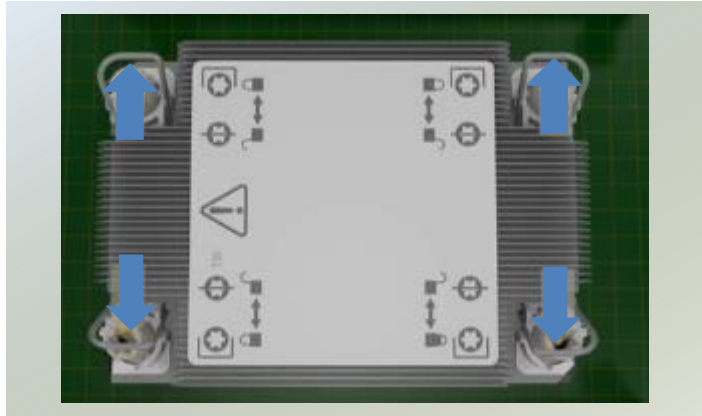

6. Check the anti-tilt wires are in locked position and have engaged the anti-tilt flanges on the bolster plate.

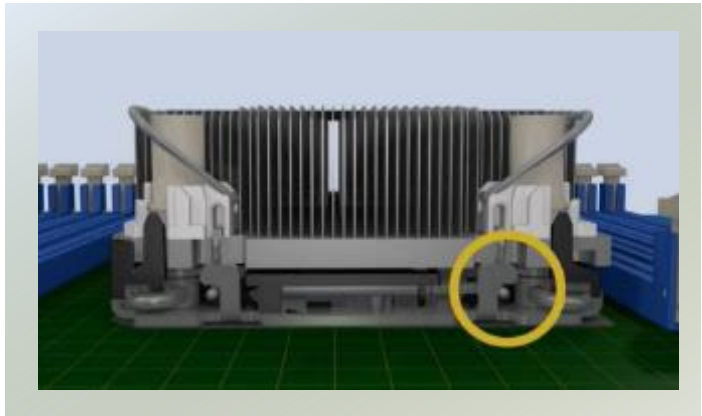

7. Use a torque driver with a T-30 Torx bit to tighten the four (4) nuts to 8 in/lb in the bolster plate.

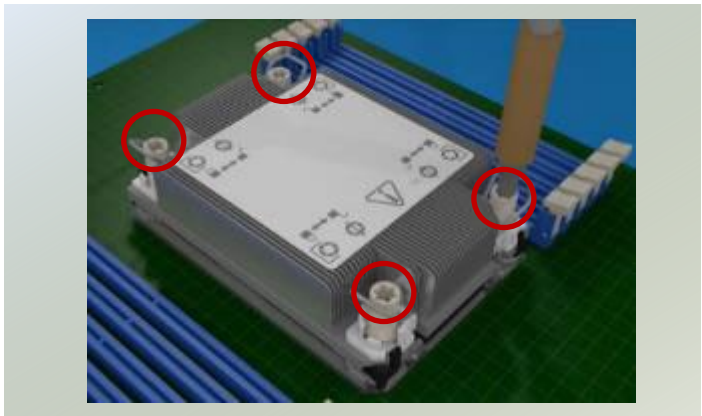

Installing the System Memory

The motherboard supports DDR4 registered DIMM memory for heavy-duty operations. Please follow the steps below to install the DIMM memory modules. The CPU have 8 DIMM channel sockets (4 on each side)

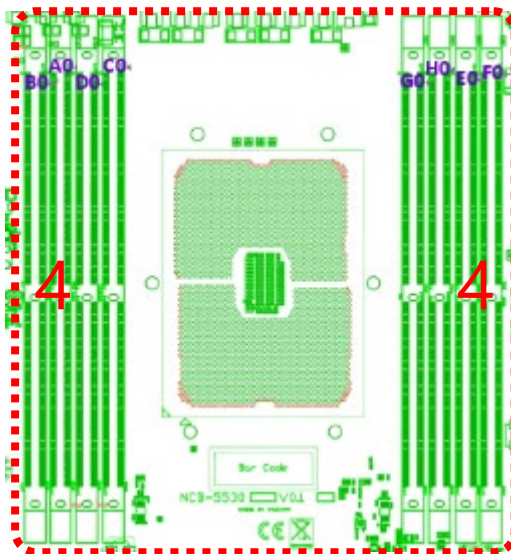

- Supported Capacities: 8/16/32/64 GB
- Maximum RAM: **512GB**

DIMM Population Guidelines:

Please do follow the memory module installation instructions to install the DIMM, and make sure the DIMM population guidelines are met:

- Each CPU requires at least 1 memory module to boot and run from.
- If you do not plan to fill up all the sockets with 24 memory modules, always start with the blue ones for optimal performance.
- Try to split the DIMMs evenly across the CPUs.
- Please use memory modules of the same capacity, speed and from the same manufacturer to avoid compatibility issues.

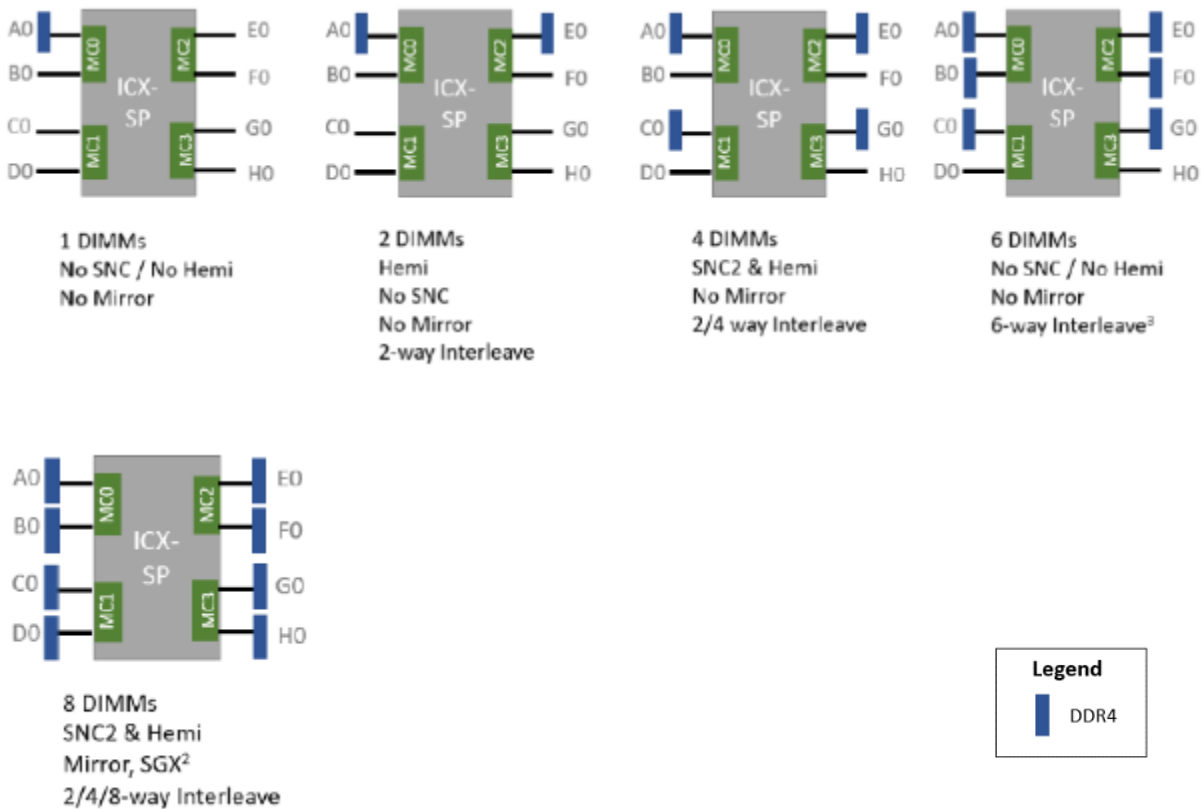

DIMM Population Notes:

- 1 DIMM: validated on any slot
- 2 DIMM: validated AE, CG, AC, EG, & AD4
- >2 DIMMs: Channel population can be different than shown as long as symmetric left/Right across the socket.
- >2 DIMMs: Configs with channel 0 populated before channel 1 on each MC are validated configs⁴
- A/E/C/G channels must be populated with same total capacity per channel if populate
- B/F/D/H channels must be populated with same total capacity if populated
- SNC2 configuration requires full asymmetry together with LEFT/RIGHT symmetry

1 – If capacity requirement not followed, all memory may not be mapped

2 – Rank sparing, ADDDC, channel mirroring, Hemi, and 2LM not supported with SGX

3 – 6 way Interleave requires same channel capacity on all 6 channels

4 – AD & ADEH additionally validated to allow for 2 different DIMM sizes in 2&4 DIMM configs.

Memory Module Installation Instructions

Please follow the steps below to install the DIMM memory modules.

1. Power off the system and open the chassis cover.
2. Pull open the DIMM slot latches.



3. Align the notch of the DIMM module with the socket key in the slot.

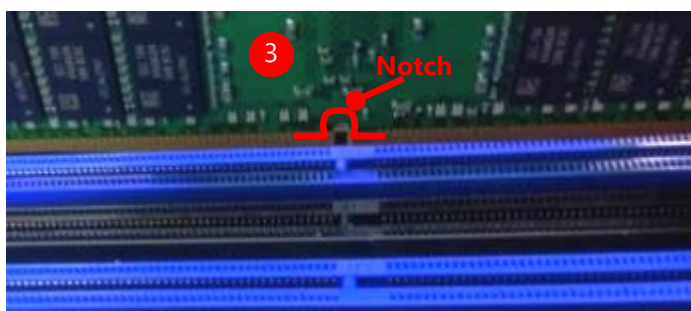

4. Insert the module into the slot until it is firmly seated. The motherboard of NCA-5530 is designed with eight (8) DDR DIMM sockets. (photo image for reference only)

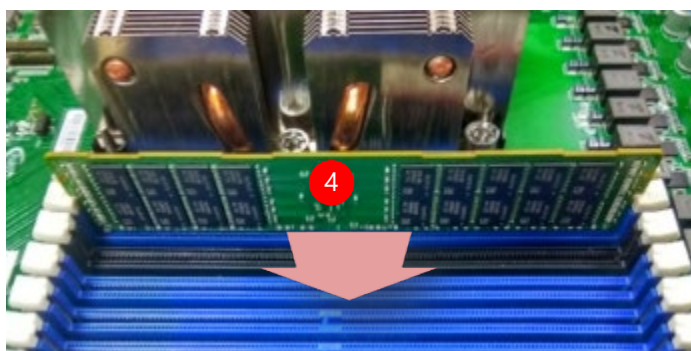

Installing TPM Module (Optional)

The motherboard provides one TPM slot. Follow the procedures below for installing a TPM module.

1. Power off the system and open the chassis cover.
2. Locate the TPM slot on the motherboard.

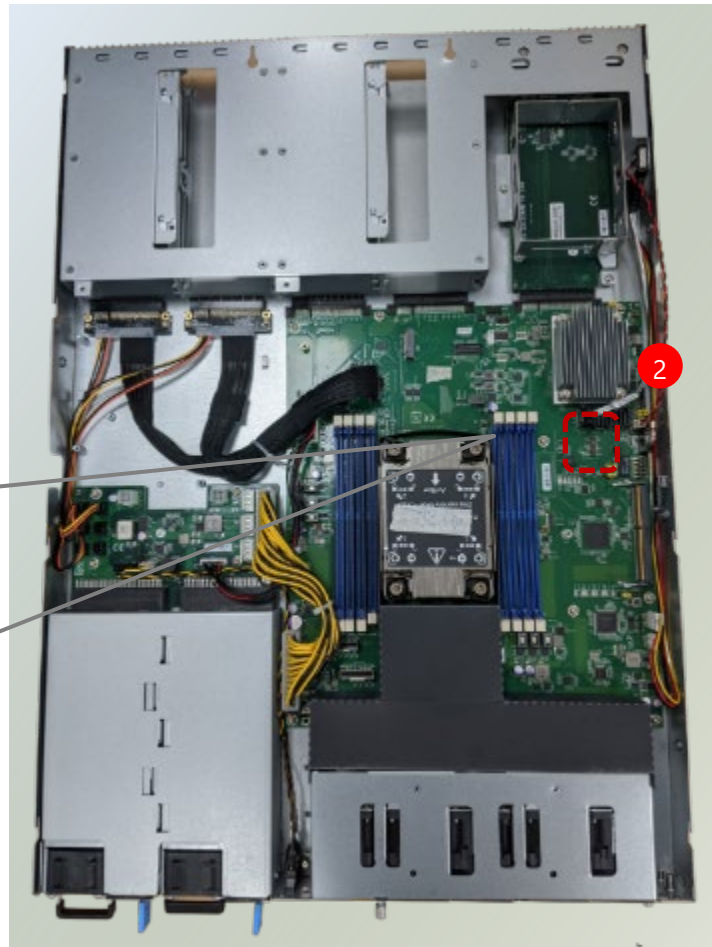
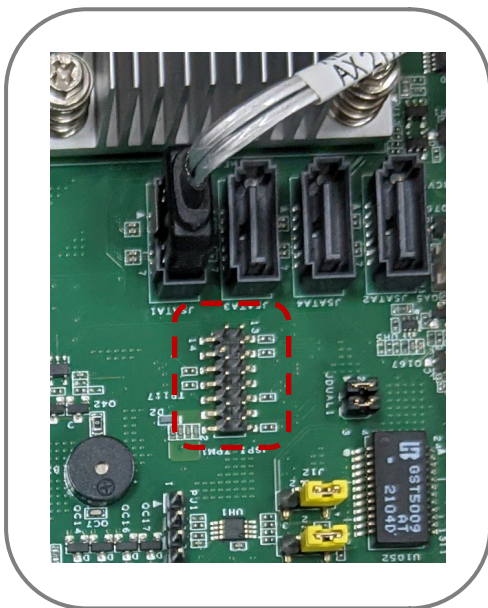

3. Insert the TPM module into the pins until it is fully seated.

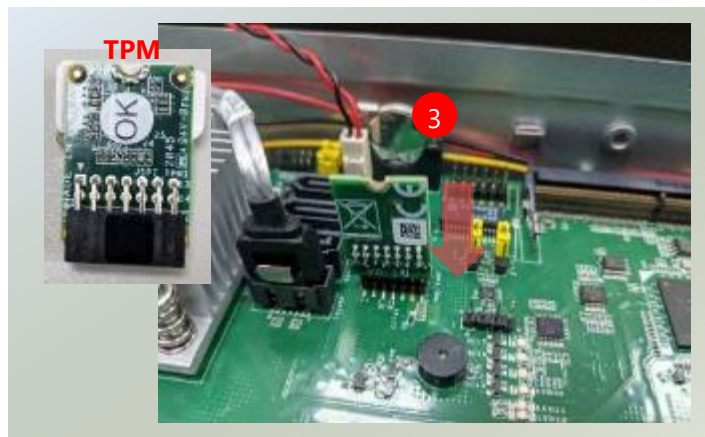

Installing the M.2 SSD memory card (Optional)

NCA-5530 comes with an additional M.2 SSD memory card slot. Please follow the steps for installation.

1. Power off the system and open the chassis cover
2. Locate the M.2 slot on the motherboard.

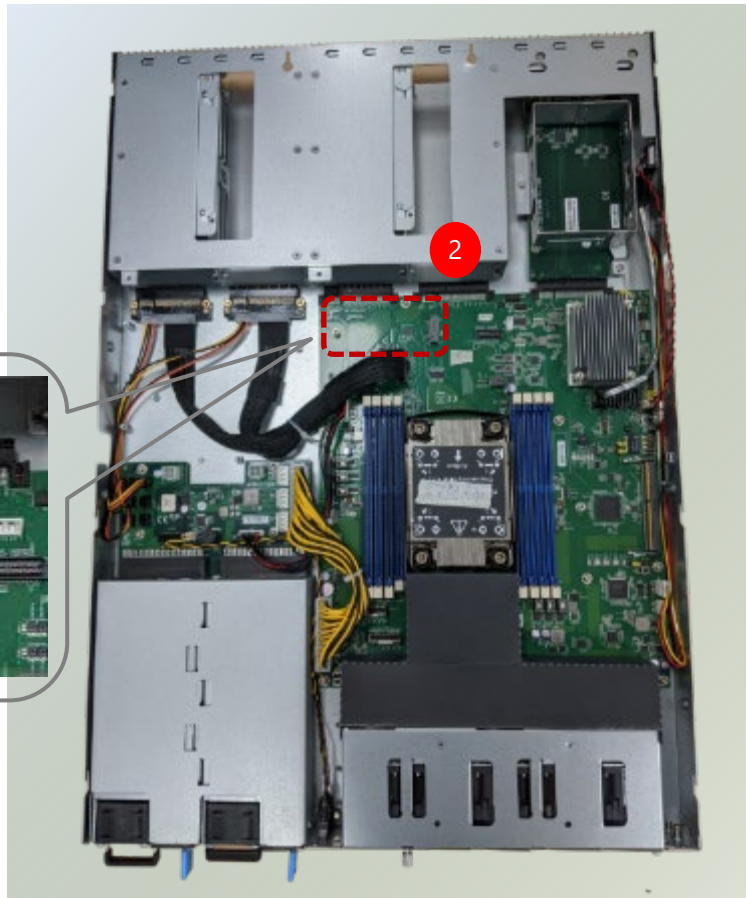
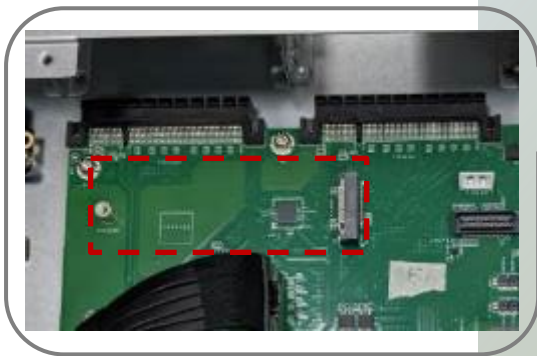

3. Align the notch of the M.2 memory card with the socket key in the pin slot.
4. Insert the M.2 memory card pins at 30 degrees into the socket until it is fully seated.



5. Push down on the module and secure it with a screw.



Installing the Disk Drive(s)

NCA-5530 is built with two 2.5" HDD/SSD slot drive bay. The following will discuss disk drive installation procedures based on their HDD/SSD designs.

1. Power off the system and open the chassis cover.
2. Locate the 2.5" disk bay.

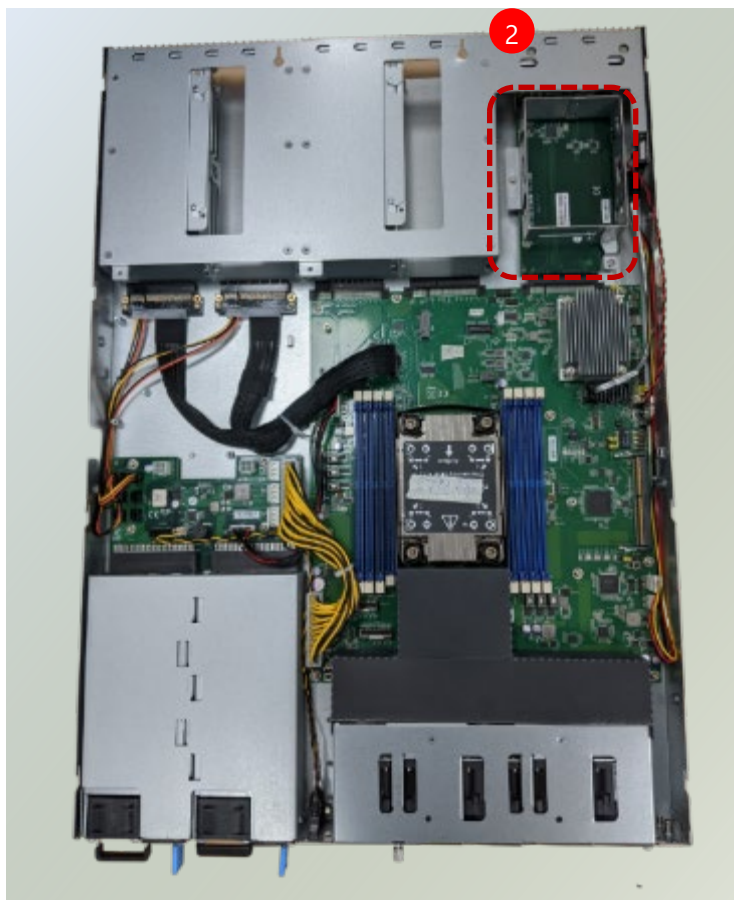

3. Loosen the three (3) screws that fix the disk tray onto the motherboard. Gently pull out the disk tray.

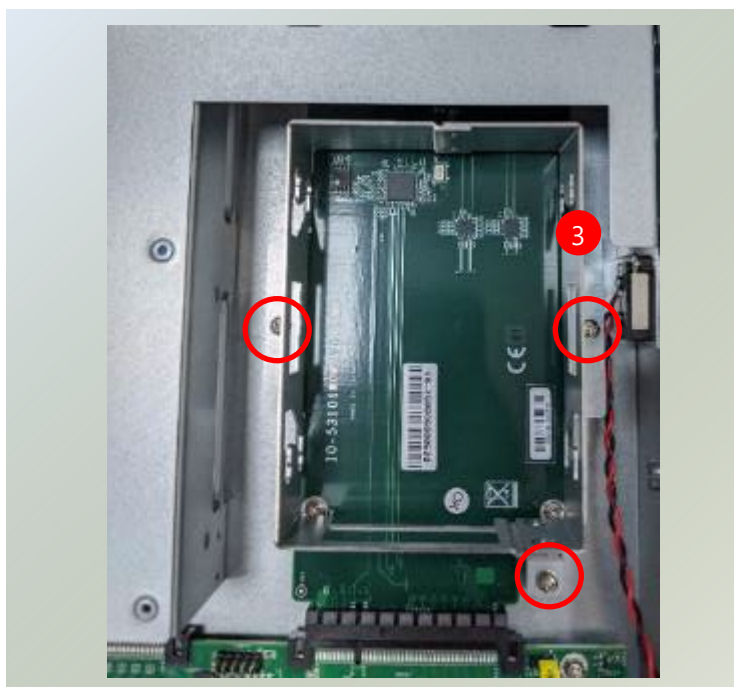

4. Mount the disk drive onto the empty tray. Make sure the disk drive's SATA contacts are facing towards the inside the system.



5. Screw in the hard disk on both sides (two (2) screws on each side).



6. Install the tray back to the original position on the motherboard and secure with the three (3) screws.



7. Connect the SATA cable and SATA power cable to the hard disk.

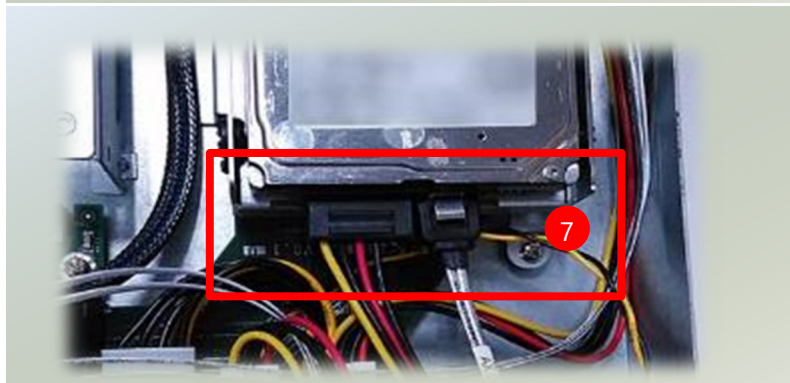

Installing the LCM Module (Optional)

NCA-5530 comes with module slots for LCM module expansion. Please follow the steps below for installation.

1. The LCM module package consists of:

- ▶ 1x LCM Panel
- ▶ 1x LCM connector cable
- ▶ 2x screws



2. Power off the system and open the chassis cover.

3. On the front panel, select the first module slot for LCM module placement.



4. Loosen the two lock-screws and remove the door.

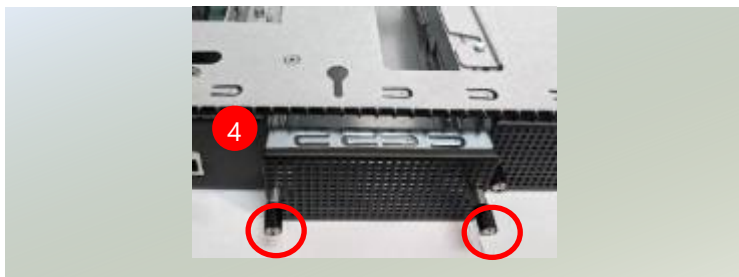

5. Locate the connector pin for LCM module cable insertion.

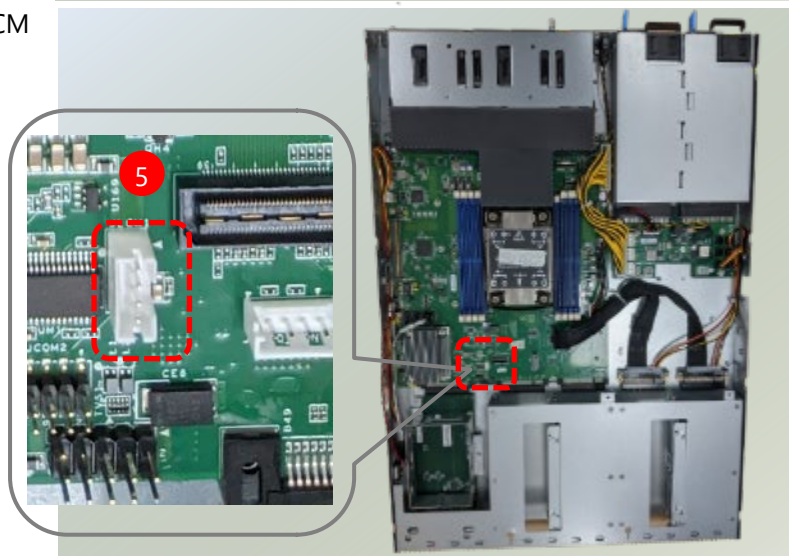

6. Install the LCM module into the module slot.

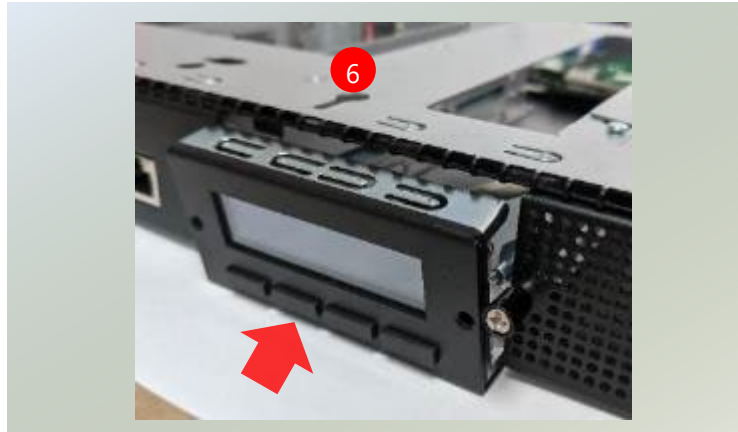

7. Insert the connector cable into the connector pin.

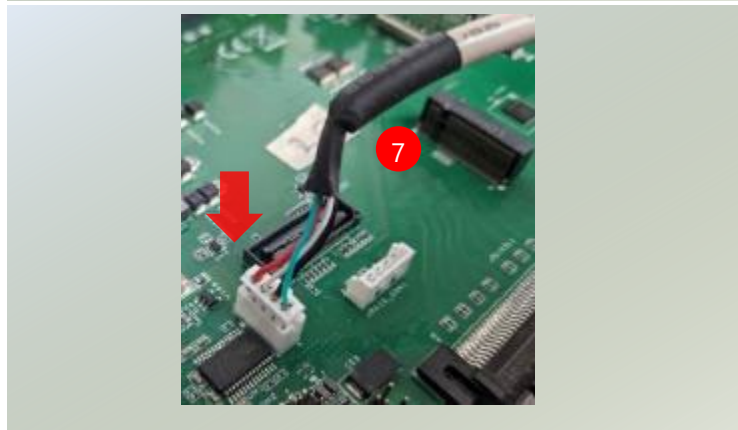

8. Secure the LCM module using the two (2) screws. Close the top cover of the system. The LCM module has been successfully installed

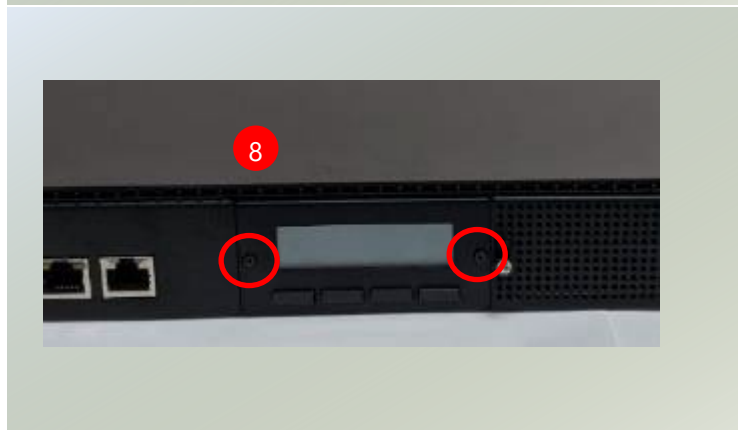

Installing the NIC Modules

NCA-5530 comes with NIC Ethernet module slots for network bandwidth expansion. Please follow the steps for installation.

1. Power off the system and open the chassis cover.
2. On the front panel, select a NIC Ethernet module slot.



3. Rotate clockwise and loosen the two (2) lock-screws and remove the door.



4. Locate the socket pin for module insertion.

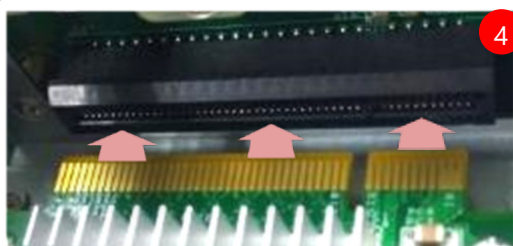
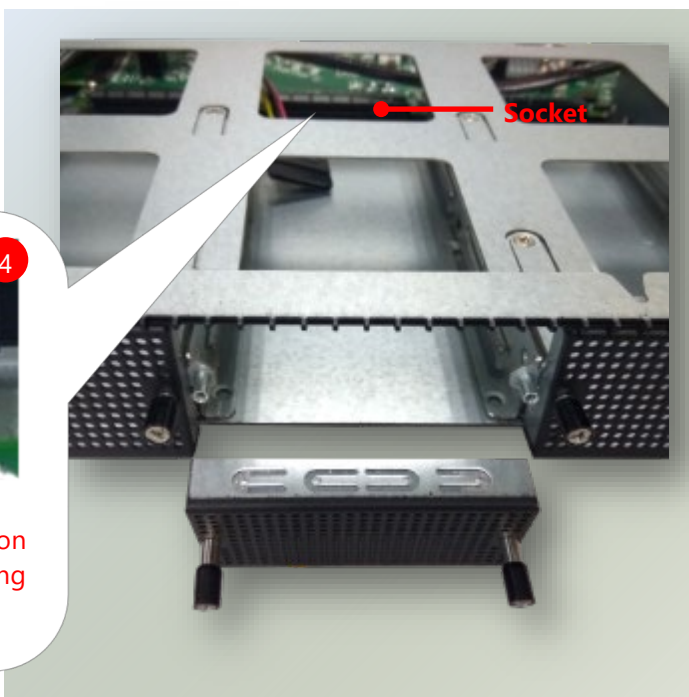

Align the golden fingers to the socket on the motherboard carefully while inserting this module.

5. Insert the NIC module. (Module shown in the image is for reference only).

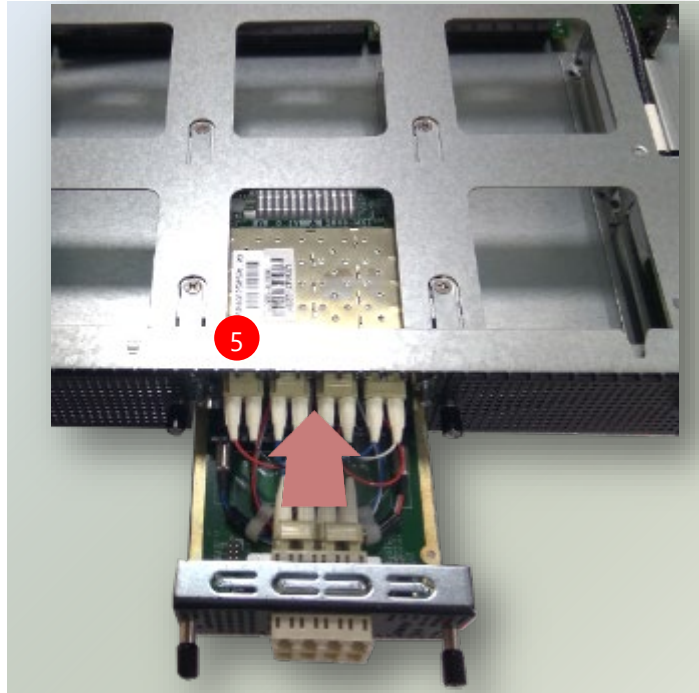

6. Once the module is firmly seated, rotate counter-clockwise and tighten the two (2) lock-screws.



Installing the IPMI card

The motherboard provides one IPMI slot. Follow the procedures below for installing an IPMI card.

1. Power off the system and open the chassis cover.
2. Locate the IPMI socket on the motherboard.

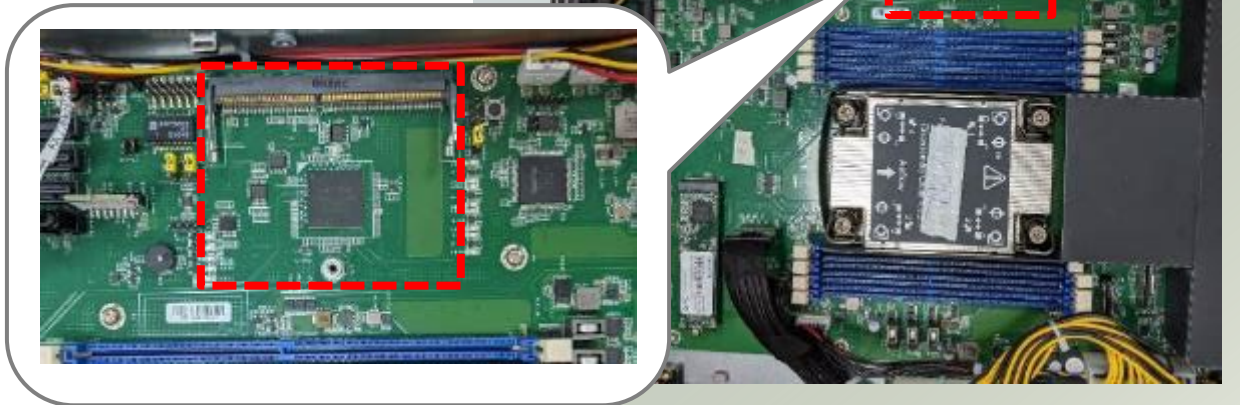

3. Align the notch of the IPMI card with the socket key in the slot.
4. Insert at 30 degrees into the socket until it is fully seated in the connector.

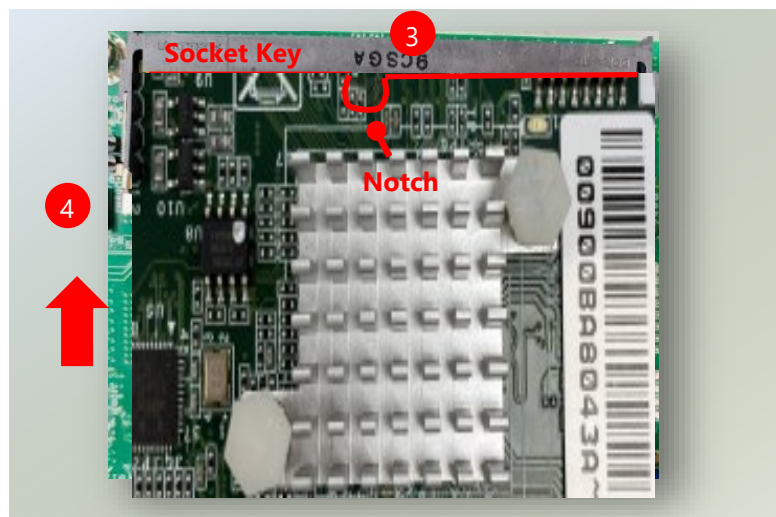

5. Push down on the IPMI card and secure it with one (1) screw.

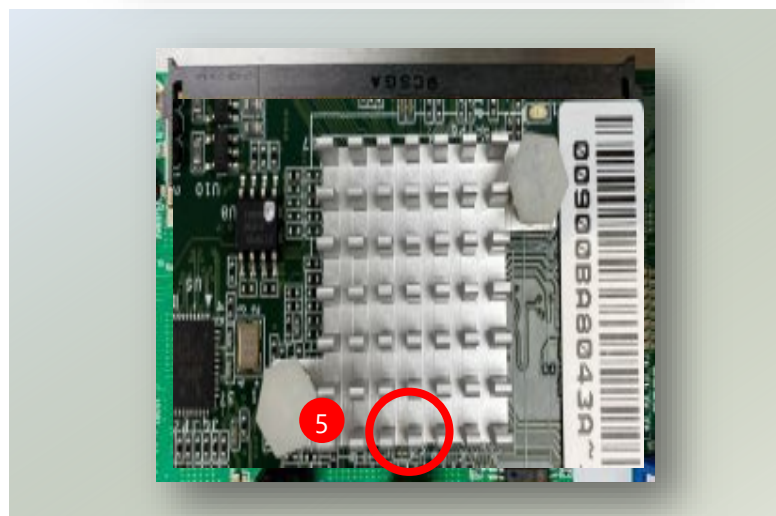

Replacing the Cooling Fans

Cooling fans may wear down eventually. Please refer to the steps below for replacing cooling fans. When using a new cooling fan, just reverse the steps to install the fan back onto the enclosure and the system.

1. On the rear panel, loosen the lock-screw of the fan you would like to replace.



2. Hold onto the lock-screw and pull out the single fan. Disconnect its power cable connect from the motherboard.



3. Install a new fan by reversing the above steps.

Replacing the AC Power Supply Units

Power supply units wear down eventually. Please be noted that the NCA-5530 supports only 550W PSU. Please prepare the power supply units matching this capacity.

1. On the rear panel, locate the power supply units and disconnect the power cords.

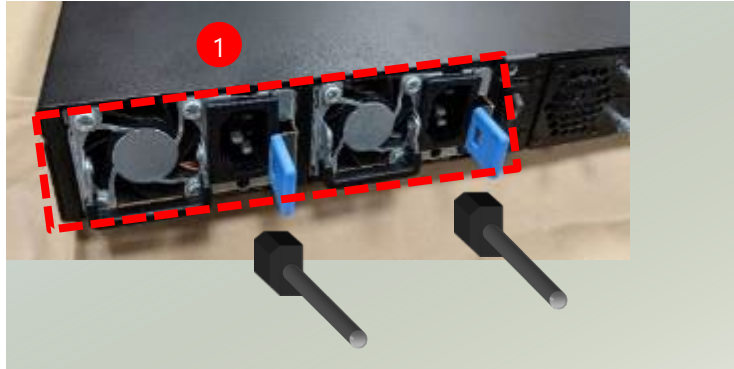

2. Hold the handle and pull out the original power supply unit.



3. Insert a new power supply unit. Push the unit until it clicks into place.



Mounting the System

The system can be installed in a rack, with the slidable rails allowing access to the system while solidly securing the system. Please follow the steps below for installation.

Attaching the Short Ear Brackets

The Ear Brackets come with six screws, as shown below.



Take an ear bracket, align the holes on it with those on the side of the system, and secure onto the system with the three (3) provided screws. Repeat to secure the other ear bracket.



Attaching the Slide Rail (Optional)

The slide rail kit shall include the following items:

1x pack screws

2x Slide-rails

Fully stretched slide rail:



Attaching Rail Brackets

1. Unpack a slide rail and slide the inner channel to its end.



2. Slide the rail bracket out to its end.



3. To detach the rail bracket from the channel, locate and push the Release Tab on the rail bracket while sliding it out.



4. Align the rail bracket to the side of the chassis and make sure the screw-holes are matched, and then secure the bracket onto the chassis with three (3) provided screws.



5. Repeat Steps 1~4 to attach the rail bracket to the other side of the chassis.



Installing the Slide Rail Assemblies

1. This slide-rail kit does NOT require screw-fixing. Aim at three (3) available screw holes on the rack front and lock it by clipping the rail's front end to the post, as shown in the image below. You should hear a "click" sound once it is firmly attached.

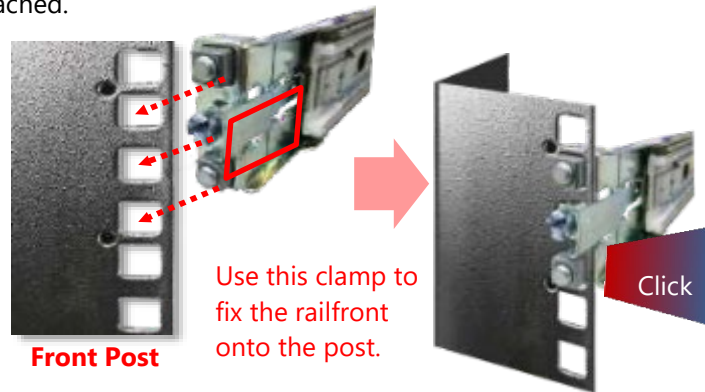

2. For the rear rack installation, slide the rail to aim and engage the bolts on the rail's rear end with the two (2) available holes on the post, and the rail assembly will click into place.

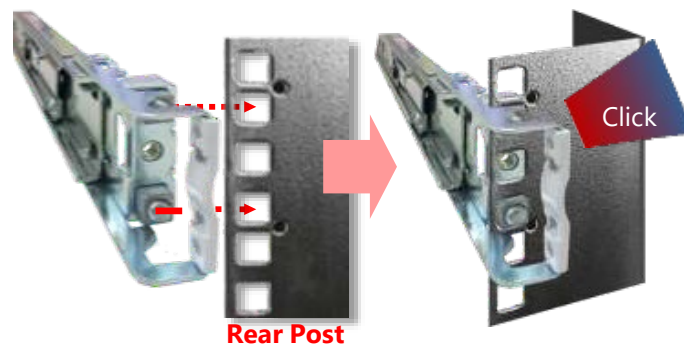

3. Repeat Steps 1~2 to install the other rail onto the post.

Installing the Chassis onto the Rack

1. Stretch both of the inner channels out to their fullest extent. You will hear a click sound when they are fully stretched and locked.



2. Hold the chassis with its front facing you, lift and gently insert it by aligning with the slide-rail assemblies as shown in the image, and then push the unit into the cabinet.



3. Keep sliding the rails in until they stop about halfway. Press down the metal clips on both inner channels and push them further into the cabinet.

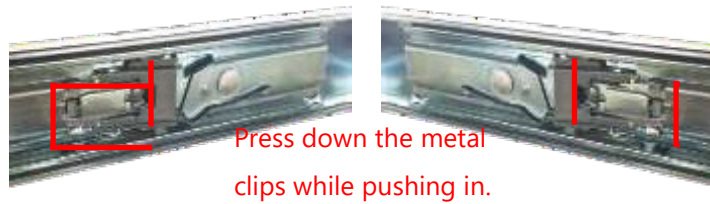

4. To have the chassis completely inserted into the rack, pull and hold the Rail Lock tab on both brackets while pushing in the chassis.



To detach the chassis from the rack, pull the Release Tabs on both sides of the brackets towards you while gently sliding the chassis out.

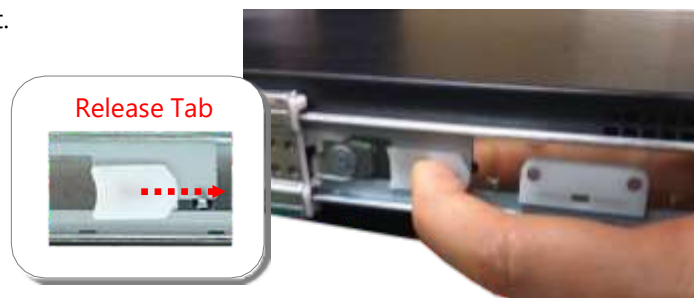

CHAPTER 3: BIOS SETUP

BIOS (Basic Input / Output System) is the program that controls the computer boot process.

Entering Setup

The system has AMI BIOS built-in, with a SETUP utility that allows users to configure required settings or to activate certain system features. Pressing the **<Tab>** or **** key immediately allows you to enter the Setup utility.

Control Keys	Description
→←	select a setup screen, for instance, [Main], [Advanced],[Platform Configuration], [Socket Configuration], [Server Mgmt], [Security], [Boot], and [Save & Exit]
↑↓	select an item/option on a setup screen
<Enter>	select an item/option or enter a sub-menu
+/-	to adjust values for the selected setup item/option
F1	to display General Help screen
F2	to retrieve previous values, such as the parameters configured the last time you had entered BIOS.
F3	to load optimized default values
F4	to save configurations and exit BIOS
<Esc>	to exit the current screen

Main

Setup main page contains BIOS information and project version information.



Feature	Description
BIOS Information	BIOS Vendor: American Megatrends Core Version: AMI Kernel version, CRB code base, X64 Compliancy : UEFI version, PI version BIOS Version : BIOS release version Build Date and Time : MM/DD/YYYY Access Level: Administrator / User
Memory Information	Total Memory: by case
System Date	To set the Date, use <Tab> to switch between Date elements. Default Range of Year: 2005-2099 Default Range of Month: 1-12 Days: dependent on Month.
System Time	To set the Date, use<Tab>to switch between Date elements.

Advanced

Select the **Advanced** menu item from the BIOS setup screen to enter the “Advanced” setup screen. Users can select any of the items in the left frame of the screen.



Trusted Computing

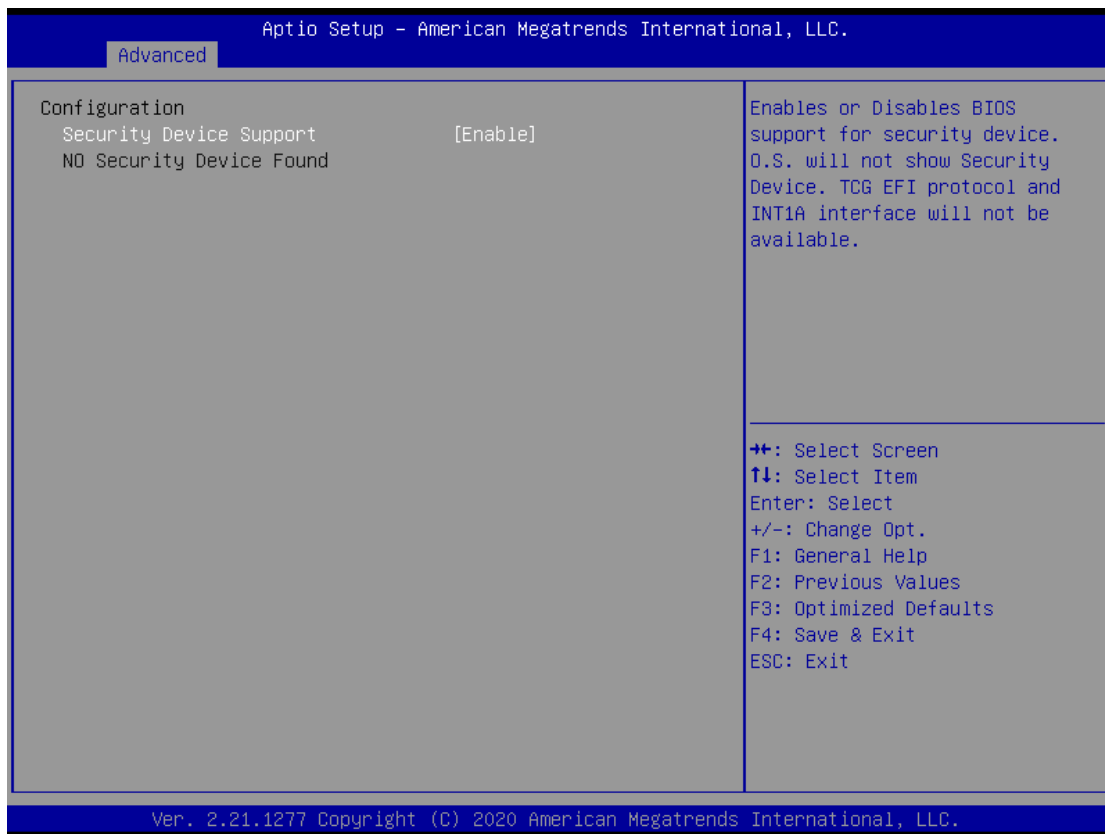

Feature	Options	Description
Security Device Support	Enabled Disabled	Enables or disables BIOS support for security device. By disabling this function, OS will not show Security Device. TCG EFI protocol and INT1A interface will not be available.

Trusted Computing (TPM 1.2)



Feature	Options	Description
Security Device Support	Enabled Disabled	Enables or disables BIOS support for security device. By disabling this function, OS will not show Security Device. TCG EFI protocol and INT1A interface will not be available.
TPM State	Enabled Disabled	Enables or disables Security Device. NOTE: Your computer will reboot during restart in order to change State of the Device.
Pending operation	None TPM Clear	Schedules an Operation for the Security Device. NOTE: Your computer will reboot during restart in order to change State of Security Device.
Device Select	TPM 1.2 TPM 2.0 Auto	TPM 1.2 will restrict support to TPM 1.2 devices; while TPM 2.0 will restrict support to TPM 2.0 devices; Auto will support both with the default set to TPM 2.0 devices.If not found, TPM 1.2 devices will be enumerated.

Trusted Computing (TPM 2.0)

Aptio Setup Utility - Copyright (C) 2017 American Megatrends, Inc.

Advanced

<p>TPM20 Device Found Vendor: NTC Firmware Version: 1.3</p> <p>Security Device [Enable] Support</p> <p>Active PCR banks SHA-1,SHA256 Available PCR banks SHA-1,SHA256</p> <p>SHA-1 PCR Bank [Enabled] SHA256 PCR Bank [Enabled]</p> <p>Pending operation [None] Platform Hierarchy [Enabled] Storage Hierarchy [Enabled] Endorsement [Enabled] Hierarchy</p>	<p>▲ Enables or Disables BIOS support for security device. O.S. will not show Security Device. TCG EFI protocol and INT1A interface will not be available.</p> <hr/> <p>↔: Select Screen ↑↓: Select Item Enter: Select +/-: Change Opt. F1: General Help F2: Previous Values F3: Optimized Defaults F4: Save & Exit ESC: Exit</p>
--	---

Version 2.19.1268. Copyright (C) 2017 American Megatrends, Inc.

AB

Aptio Setup Utility - Copyright (C) 2017 American Megatrends, Inc.

Advanced

<p>Active PCR banks SHA-1,SHA256 Available PCR banks SHA-1,SHA256</p> <p>SHA-1 PCR Bank [Enabled] SHA256 PCR Bank [Enabled]</p> <p>Pending operation [None] Platform Hierarchy [Enabled] Storage Hierarchy [Enabled] Endorsement [Enabled] Hierarchy</p> <p>TPM2.0 UEFI Spec [TCG_2] Version</p> <p>Physical Presence [1.3] Spec Version</p> <p>TPM 20 [TIS] InterfaceType</p> <p>Device Select [Auto]</p>	<p>▲ TPM 1.2 will restrict support to TPM 1.2 devices, TPM 2.0 will restrict support to TPM 2.0 devices, Auto will support both with the default set to TPM 2.0 devices if not found,</p> <hr/> <p>↔: Select Screen ↑↓: Select Item Enter: Select +/-: Change Opt. F1: General Help F2: Previous Values F3: Optimized Defaults F4: Save & Exit ESC: Exit</p>
--	--

Version 2.19.1268. Copyright (C) 2017 American Megatrends, Inc.

AB

Feature	Options	Description
Security Device Support	Enabled Disabled	Enables or disables BIOS support for security device. By disabling this function, OS will not show Security Device. TCG EFI protocol and INT1A interface will not be available.
SHA-1 PCR Bank	Enabled Disabled	Enables or disables SHA-1 PCR Bank.
SHA256 PCR Bank	Enabled Disabled	Enables or disables SHA256 PCR Bank.
Pending operation	None TPM Clear	Schedules an Operation for the Security Device. NOTE: Your computer will reboot during restart in order to change State of Security Device.
Platform Hierarchy	Enabled Disabled	Enables or disables Platform Hierarchy.
Storage Hierarchy	Enabled Disabled	Enables or disables Storage Hierarchy.
Endorsement Hierarchy	Enabled Disabled	Enables or disables Endorsement Hierarchy.
TPM2.0 UEFI Spec Version	TCG_1_2 TCG_2	Select the TCG2 Spec Version, TCG_1_2: Supports the Compatible mode for Win8/Win10 TCG_2: Supports new TCG2 protocol and event format for Win10 or later.
Physical Presence Spec Version	1.2 1.3	Select to tell OS to support PPI Spec Version 1.2 or 1.3. NOTE: Some HCK tests might not support 1.3.
TPM 20 InterfaceType	TIS	Select TPM 20 Device for the Communication Interface.
Device Select	TPM 1.2 TPM 2.0 Auto	TPM 1.2 will restrict support to TPM 1.2 devices; while TPM 2.0 will restrict support to TPM 2.0 devices; Auto will support both with the default set to TPM 2.0 devices. If not found, TPM 1.2 devices will be enumerated.

Super IO Configuration



Serial Port 1 Configuration

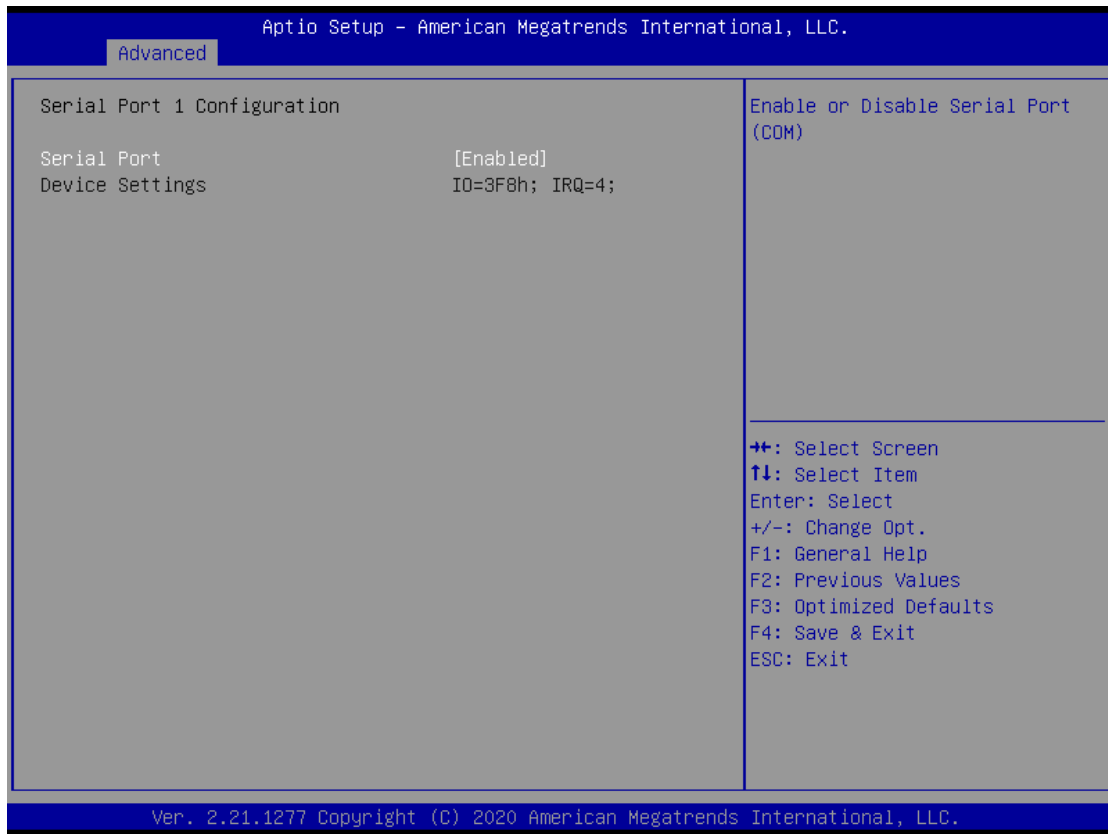

Feature	Options	Description
Serial Port	Enabled Disabled	Enables or disables Serial Port 1.
Device Settings	NA	IO=3F8h; IRQ = 4

Serial Port 2 Configuration

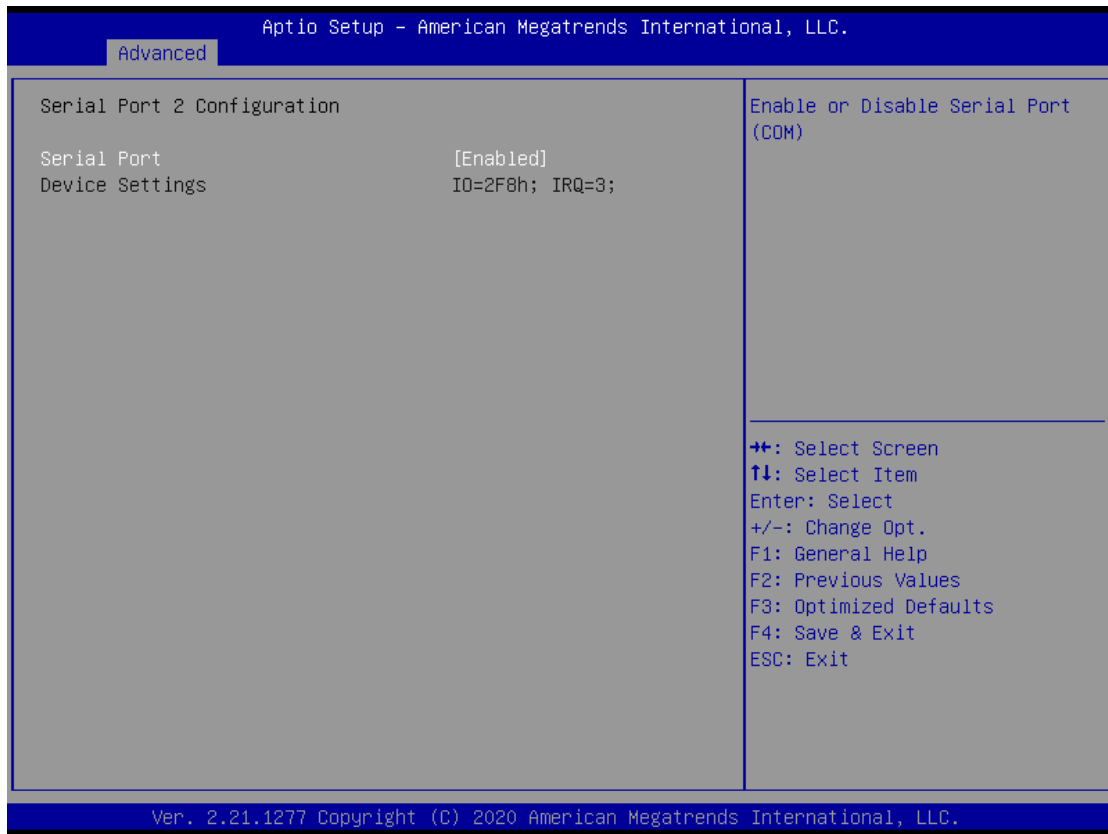

Feature	Options	Description
Serial Port	Enabled Disabled	Enables or disables Serial Port 2
Device Settings	NA	IO=2F8h; IRQ = 3

H/W Monitor

The screenshot displays the 'Advanced' tab of the 'Aptio Setup - AMI' utility. The main content area is titled 'Pc Health Status' and contains a table of voltage readings. To the right of the table is a list of navigation instructions. At the bottom of the screen, the version number and copyright information are displayed, along with a small 'AB' logo in the bottom right corner.

Pc Health Status	
PVCCANA	: +0.984 V
12V	: +11.808 V
5V	: +4.880 V
VSB5V	: +4.840 V
PVCC1V8	: +1.757 V
3.3V	: +3.280 V
VSB3.3V	: +3.296 V
VBAT	: +2.960 V

++: Select Screen
↑↓: Select Item
Enter: Select
+/-: Change Opt.
F1: General Help
F2: Previous Values
F3: Optimized Defaults
F4: Save & Exit
ESC: Exit

Version 2.21.1278 Copyright (C) 2021 AMI

AB

NCT7904D HW Monitor

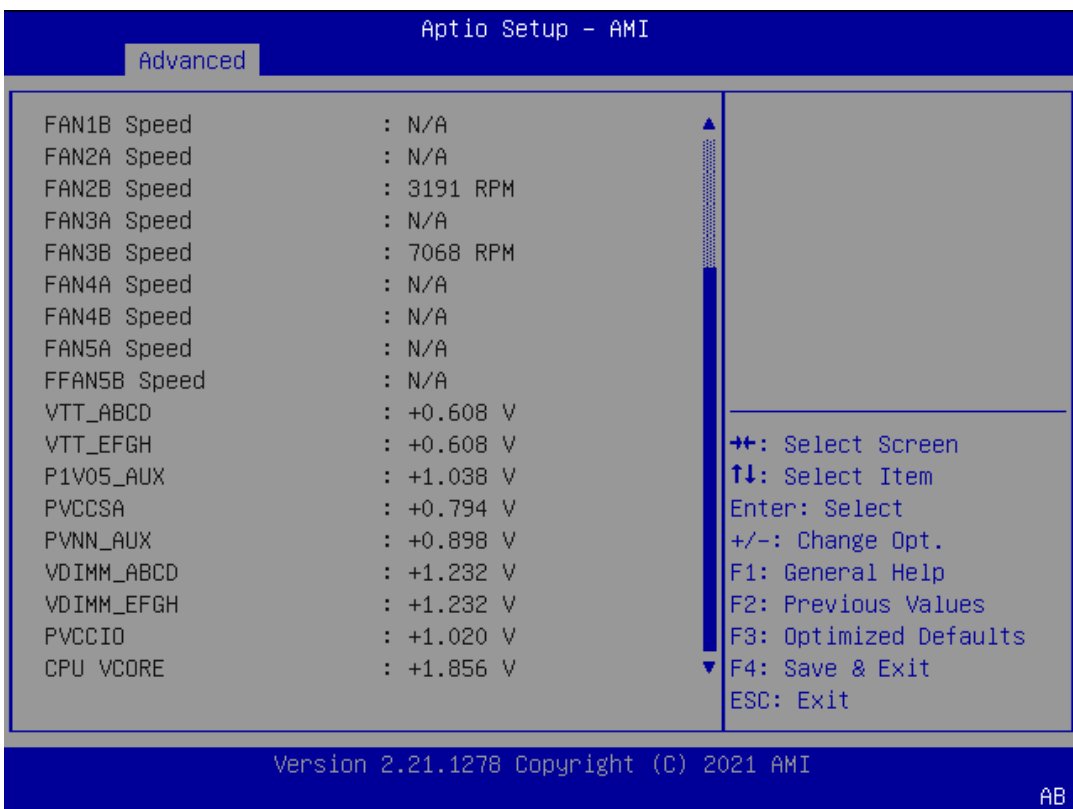
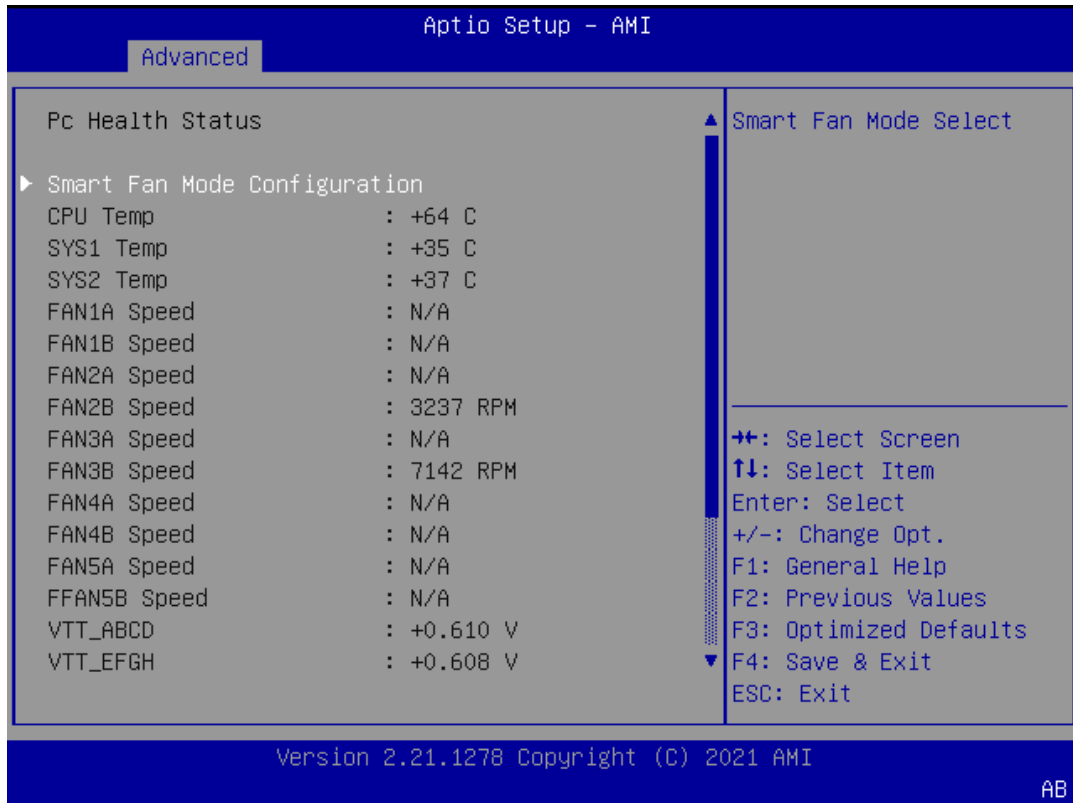

Feature	Options	Description
Smart Fan Mode Configuration	None	Smart Fan Parameters

Smart Fan Mode Configuration

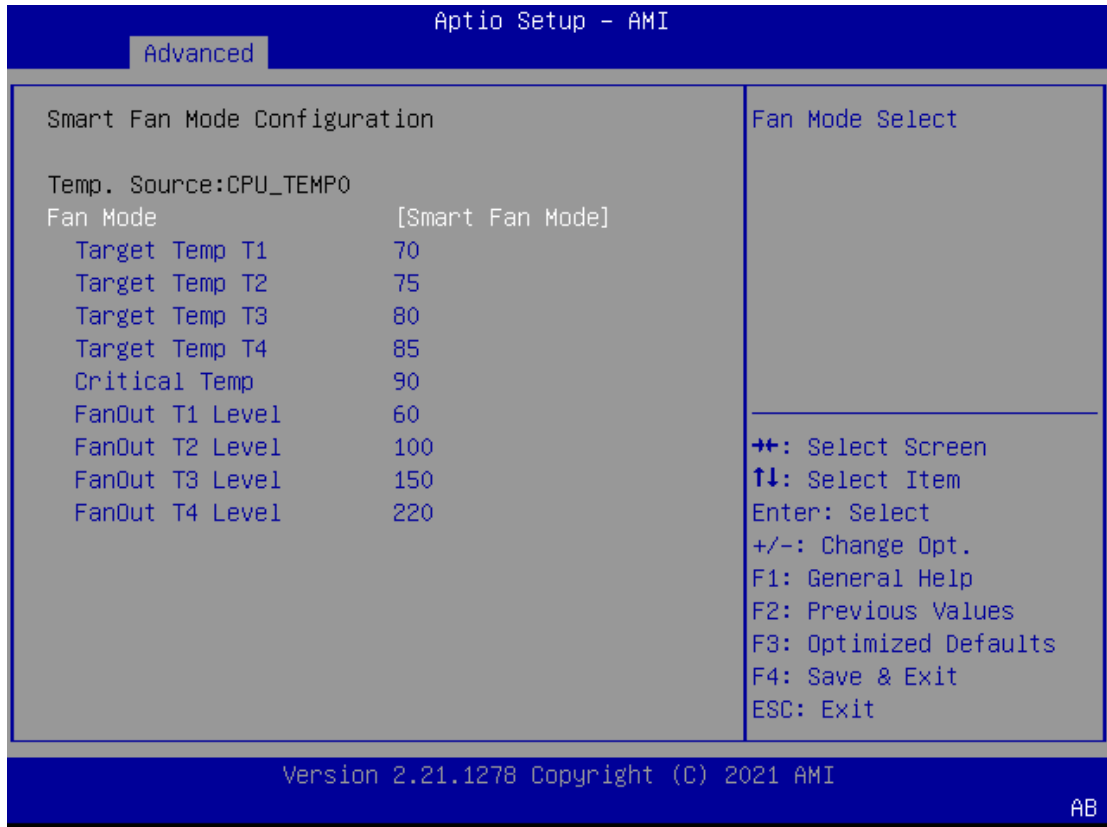

Feature	Options	Description
Smart Fan Mode	Manual Mode Smart Fan Mode	Smart Fan Mode select
Target Temperature T1	70	Input Target Temperature (Range:0 - 127)
Target Temperature T2	75	Input Target Temperature (Range:0 - 127)
Target Temperature T3	80	Input Target Temperature (Range:0 - 127)
Target Temperature T4	85	Input Target Temperature (Range:0 - 127)
Critical Temperature	90	Input Target Temperature (Range:0 - 127)
FanOut T1 Level	60	Input Target Fan Out
FanOut T2 Level	100	Input Target Fan Out
FanOut T3 Level	150	Input Target Fan Out
FanOut T4 Level	220	Input Target Fan Out
Smart Fan Mode	Manual Mode Smart Fan Mode	Smart Fan Mode select

Serial Port Console Redirection

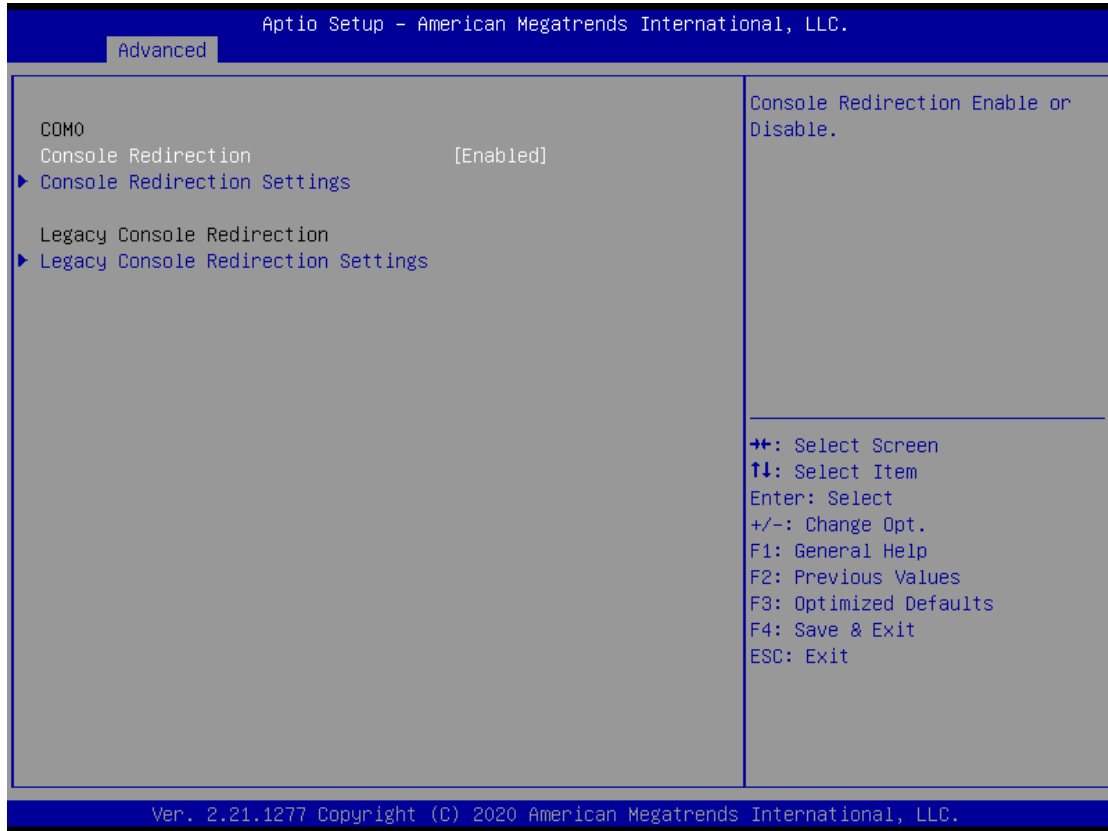

Feature	Options	Description
COM0 Console Redirection	Enabled Disabled	Enables or disables Console Redirection

Console Redirection Settings



Feature	Options	Description
Terminal Type	VT100 VT100+ VT-UTF8 ANSI	VT100: ASCII char set VT100+: Extends VT100 to support color, function keys, etc. VT-UTF8: Uses UTF8 encoding to map Unicode chars onto 1 or more bytes ANSI: Extended ASCII char set
Bits per second	9600 19200 38400 57600 115200	Selects serial port transmission speed. The speed must be matched on the other side. Long or noisy lines may require lower speeds.
Data Bits	7 8	Data Bits
Parity	None Even Odd Mark Space	A parity bit can be sent with the data bits to detect some transmission errors.
Stop Bits	1 2	Indicates the end of a serial data packet.
Flow Control	None Hardware RTS/CTS	Flow Control can prevent data loss from buffer overflow.

VT-UTF8 Combo Key Support	Disabled Enabled	Enables VT-UTF8 Combination Key Support for ANSI/VT100 terminals
Recorder Mode	Disabled Enabled	With this mode enabled, only text will be sent. This is to capture Terminal data.
Resolution 100x31	Disabled Enabled	Enables or disables extended terminal resolution
Putty KeyPad	VT100 LINUX XTERM86 SCO ESCN VT400	Selects FunctionKey and KeyPad on Putty.

Legacy Console Redirection Settings



Feature	Options	Description
Legacy Serial Redirection Port	COM0	Select a COM port to display redirection of Legacy OS and Legacy OPROM Messages
Legacy OS Redirection Resolution	80x24 80x25	On Legacy OS, the Number of Rows and Columns supported redirection.
Redirection After BIOS POST	Always Enable BootLoader	When Bootloader is selected, Legacy Console Redirection is disabled before booting to legacy OS. When Always Enable is selected, then Legacy Console Redirection is enabled for legacy OS. Default setting for this option is set to Always Enable .

PCI Subsystem Settings

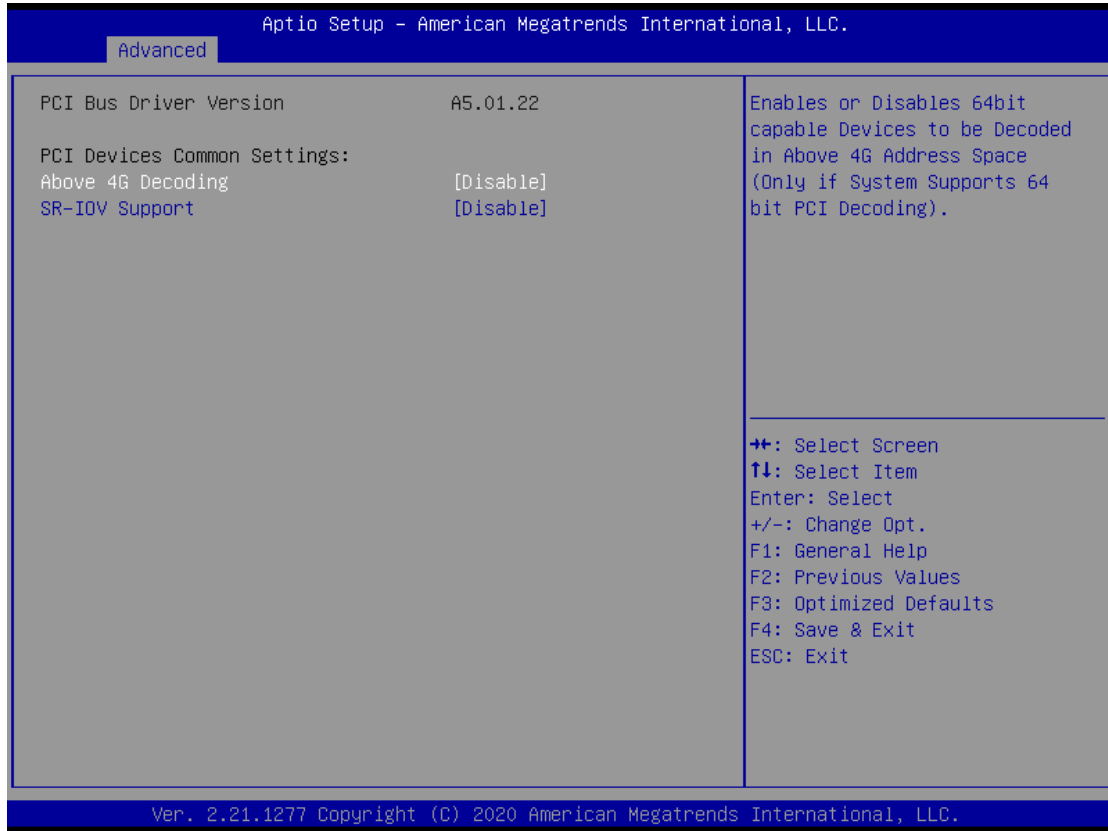

Feature	Options	Description
Above 4G Decoding	Disabled Enabled	Enables or disables 64bit capable Devices to be Decoded in Above 4G Address Space (Only if System Supports 64 bit PCI Decoding)
SR-IOV Support	Disabled Enabled	If the system has SR-IOV capable PCIe Devices, this option enables or disables Single Root IO Virtualization Support.

USB Configuration

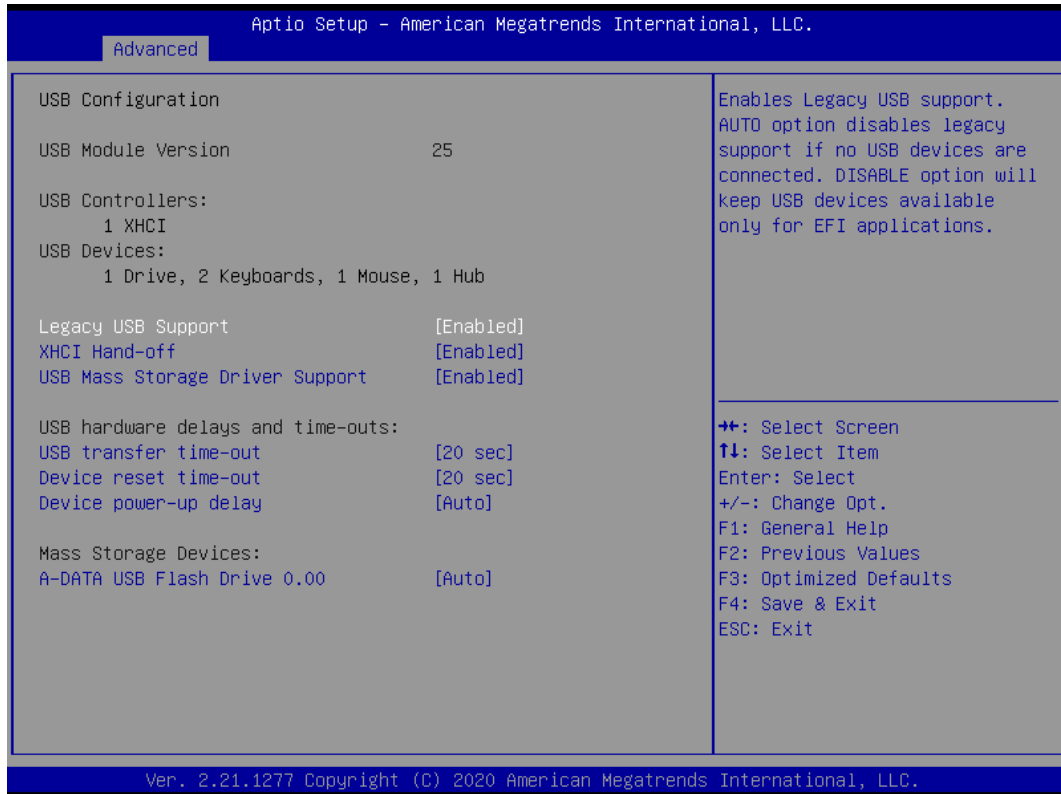

Feature	Options	Description
Legacy USB Support	Enabled Disabled Auto	Enables Legacy USB support. AUTO option disables legacy support if no USB devices are connected; DISABLED option will keep USB devices available only for EFI applications.
XHCI Hand-off	Enabled Disabled	This is a workaround for OSEs without XHCI hand-off support. The XHCI ownership change should be claimed by XHCI driver.
USB Mass Storage Driver Support	Enabled Disabled	Enables or disables USB Mass Storage Driver Support.
USB transfer time-out	1 sec 5 sec 10 sec 20 sec	The time-out value for Control, Bulk, and Interrupt transfers
Device reset time-out	1 sec 5 sec 10 sec 20 sec	USB mass storage device Start Unit command time-out
Device power-up delay	Auto Manual	Maximum time the device will take before it properly reports itself to the Host Controller. Auto uses default value: for a Root port, it is 100 ms, for a Hub port the delay is taken from Hub descriptor.

Network Stack Configuration

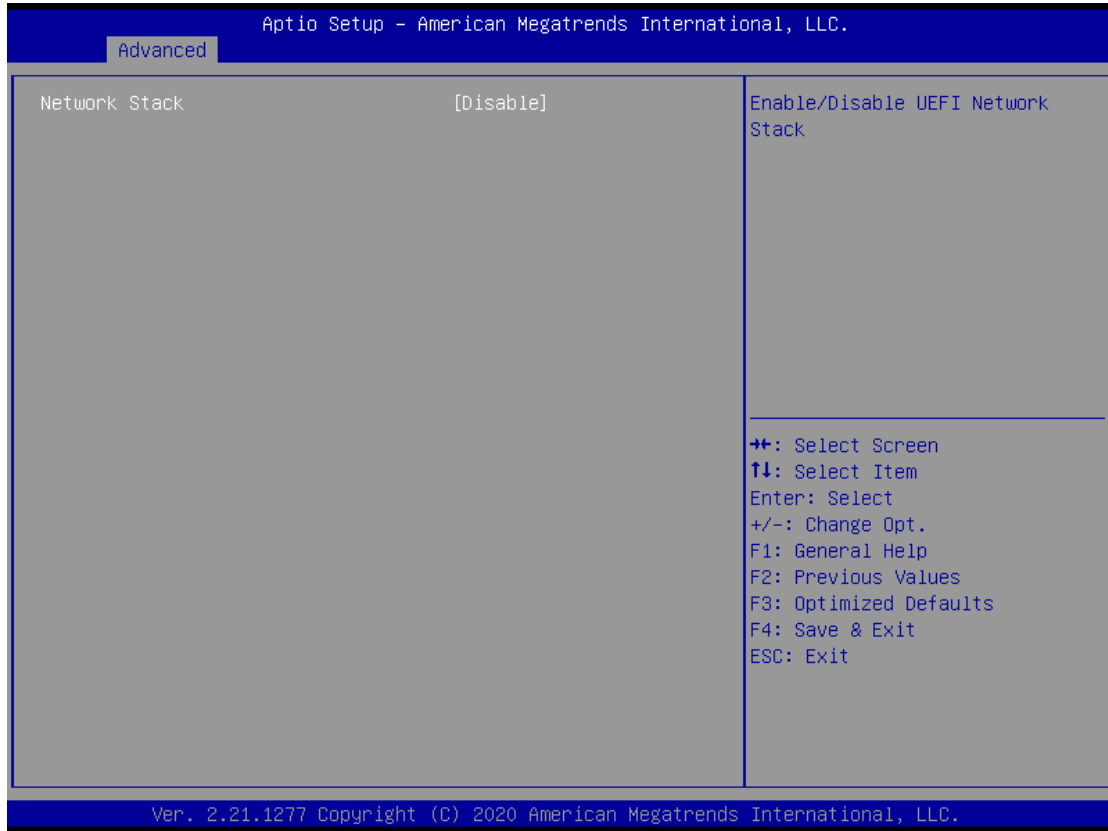

Feature	Options	Description
Network Stack	Disabled Enabled	Enables or disables UEFI Network Stack
Ipv4 PXE Support	Disabled Enabled	Enables Ipv4 PXE Boot Support. If IPV4 is disabled, PXE boot option will not be created.
Ipv4 HTTP Support	Disabled Enabled	Enables Ipv4 HTTP Boot Support. If IPV4 is disabled, HTTP boot option will not be created.
Ipv6 PXE Support	Disabled Enabled	Enables Ipv6 PXE Boot Support. If IPV6 is disabled, PXE boot option will not be created.
Ipv6 HTTP Support	Disabled Enabled	Enables Ipv6 HTTP Boot Support. If IPV6 is disabled, HTTP boot option will not be created.
PXE boot wait time	0	Wait time to press <ESC> key to abort the PXE boot
Media detect count	1	Number of times the presence of media will be checked

CSM Configuration

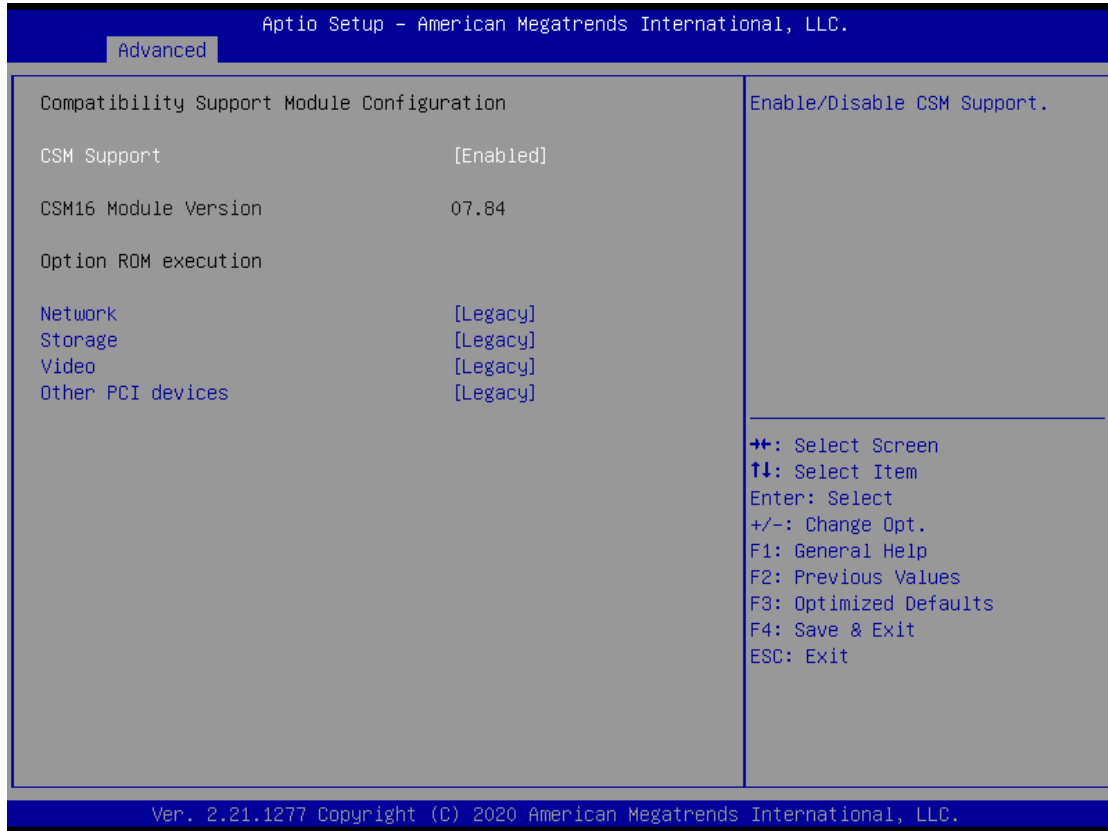

Feature	Options	Description
CSM Support	Disabled Enabled	Enables or disables CSM Support
Network	Do Not Launch UEFI Legacy	Controls the execution of UEFI and Legacy PXE OpROM
Storage	Do Not Launch UEFI Legacy	Controls the execution of UEFI and Legacy Storage OpROM
Video	Do Not Launch UEFI Legacy	Controls the execution of UEFI and Legacy Video OpROM
Other PCI device	Do Not Launch UEFI Legacy	Determines OpROM execution policy for devices other than Network, Storage, or Video

NVMe Configuration

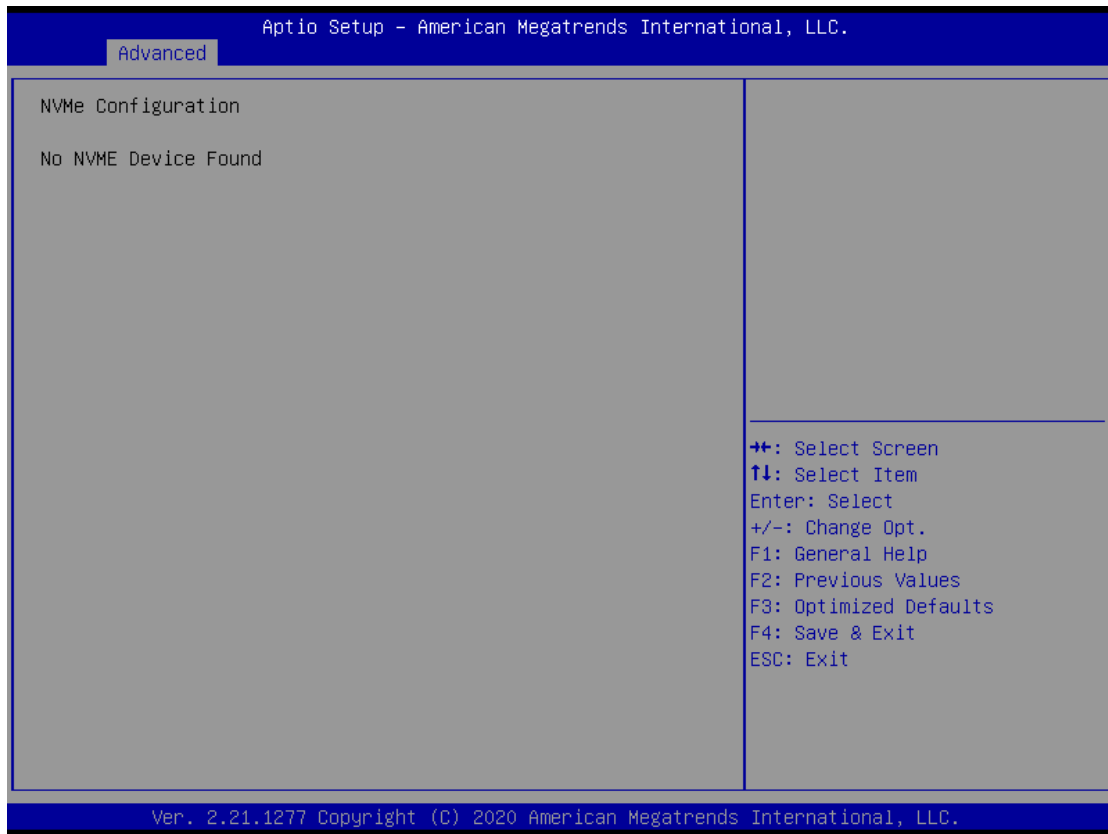

Control Legacy PXE Boot

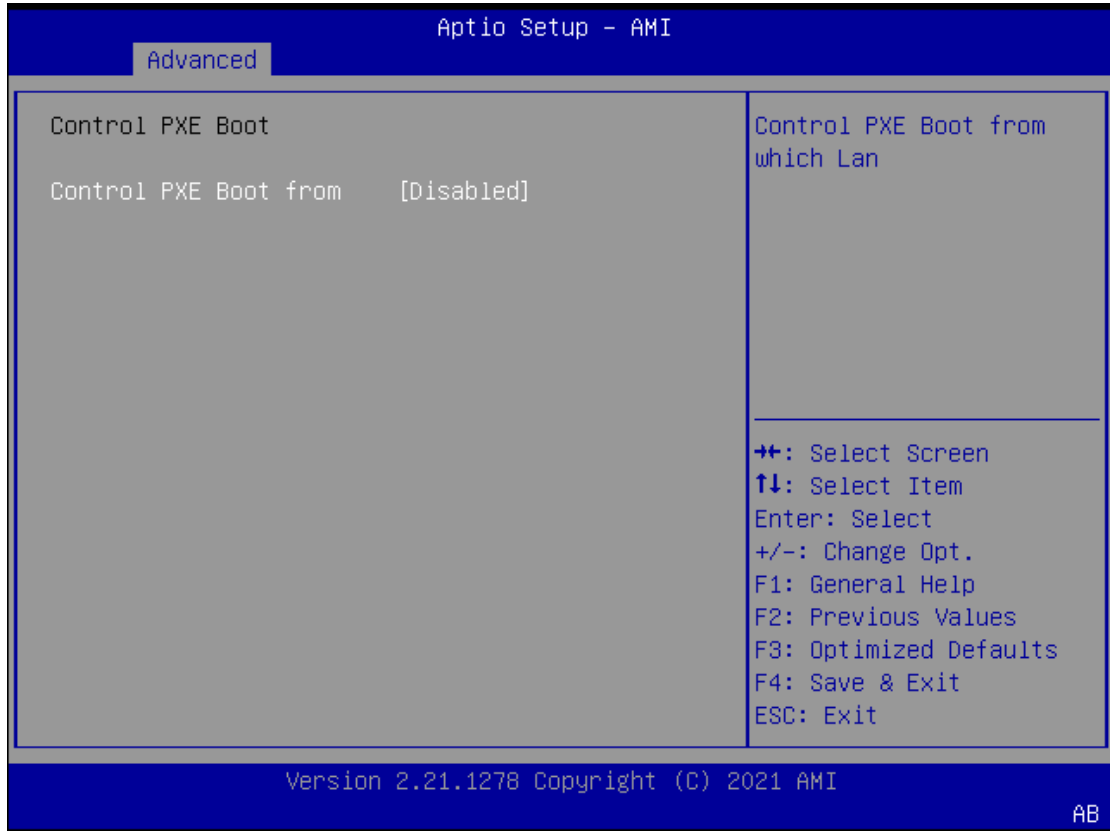

Feature	Options	Description
Control Legacy PXE Boot from	Disabled LAN	Select On Board LAN# Boot

Platform Configuration

Select the Platform menu item from the BIOS setup screen to enter the "Platform Setup" screen. Users can select any of the items in the left frame of the screen.

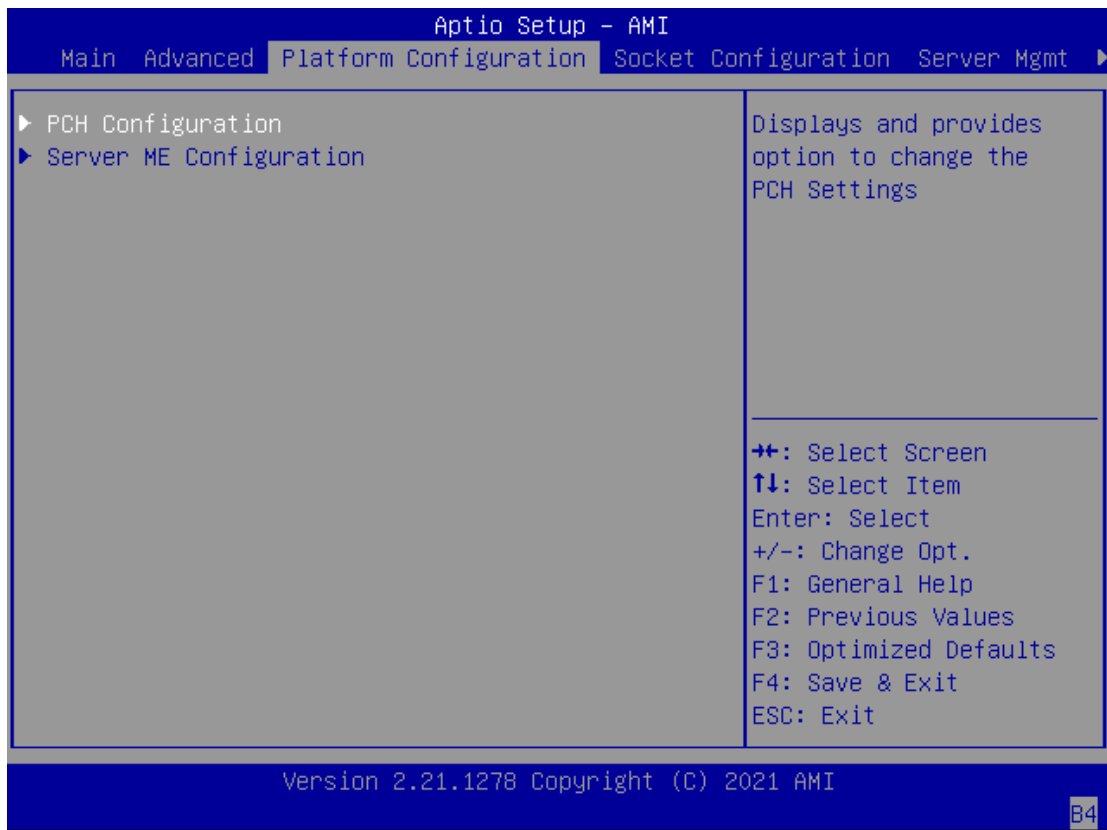

Feature	Options	Description
PCH Configuration	None	Displays and provides option to change the PCH Settings
Server ME Configuration	None	Configure Server ME Technology Parameters
Runtime Error Logging	None	Press <Enter> to view or change the runtime error log configuration.

PCH Configuration

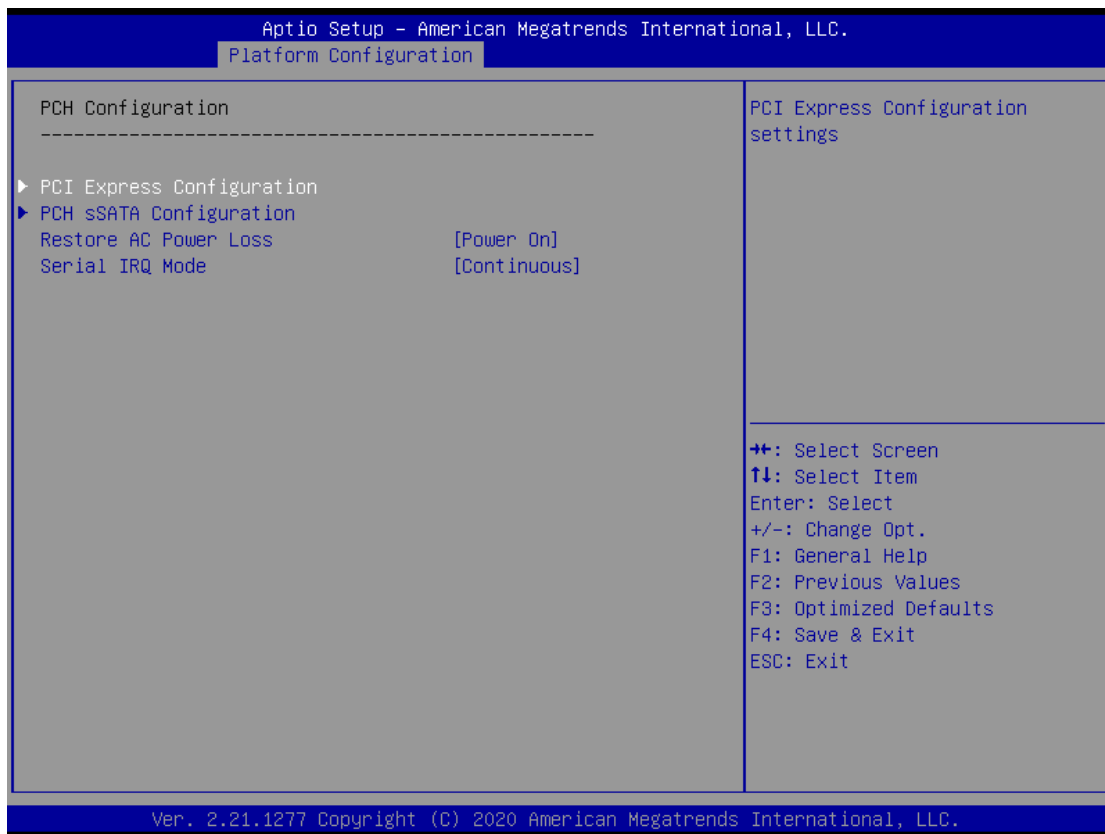

Feature	Options	Description
PCI Express Configuration	None	PCI Express Configuration settings
PCH sSATA Configuration	None	sSATA devices and settings
Restore AC Power Loss	Power ON Power Off Last State	Select S0/S5 for ACPI state after a G3
Serial IRQ Mode	Quiet Continuous	Configure Serial IRQ Mode.

PCI Express Configuration

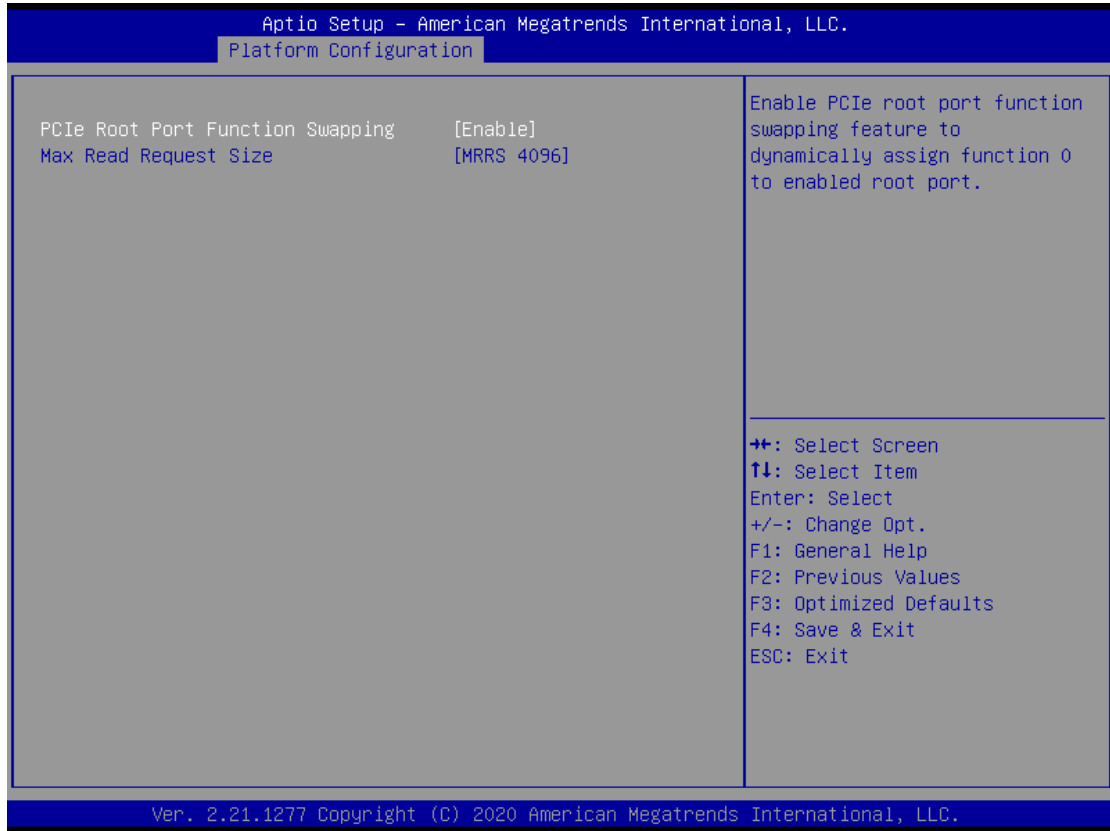

Feature	Options	Description
PCIe Root Port Function Swapping	Disabled Enabled	Enable PCIe root port function swapping feature to dynamically assign function 0 to enabled root port.
Max Read Request Size	MRRS 128B MRRS 256B MRRS 512B MRRS 1024B MRRS 2048B MRRS 4096B	PCIE Max Read Request Size Selection.

PCH sSATA Configuration

Aptio Setup - American Megatrends International, LLC.
Platform Configuration

PCH sSATA Configuration		Enable or Disable SATA Controller
ssATA Controller	[Enable]	▲ Enable or Disable SATA Controller ++: Select Screen ↑↓: Select Item Enter: Select +/-: Change Opt. F1: General Help F2: Previous Values F3: Optimized Defaults F4: Save & Exit ESC: Exit
Configure ssATA as	[AHCI]	
Support Aggressive Link Power Management	[Disable]	
ssATA Port 0	[Not Installed]	
Port 0	[Enable]	
Hot Plug	[Disable]	
Configure as eSATA	[Disable]	
Spin Up Device	[Disable]	
sSATA Device Type	[Hard Disk Drive]	
SATA Topology	[Unknown]	
ssATA Port 2	[Not Installed]	
Port 2	[Enable]	
Hot Plug	[Disable]	
Configure as eSATA	[Disable]	
Spin Up Device	[Disable]	
sSATA Device Type	[Hard Disk Drive]	
SATA Topology	[Unknown]	
ssATA Port 3	[Not Installed]	
Port 3	[Enable]	
Hot Plug	[Disable]	

Ver. 2.21.1277 Copyright (C) 2020 American Megatrends International, LLC.

Aptio Setup - American Megatrends International, LLC.
Platform Configuration

Configure as eSATA	[Disable]	▲ Identify the Secondary SATA Topology if it is Default or ISATA or Flex or DirectConnect or M2 ++: Select Screen ↑↓: Select Item Enter: Select +/-: Change Opt. F1: General Help F2: Previous Values F3: Optimized Defaults F4: Save & Exit ESC: Exit
Spin Up Device	[Disable]	
sSATA Device Type	[Hard Disk Drive]	
SATA Topology	[Unknown]	
ssATA Port 3	[Not Installed]	
Port 3	[Enable]	
Hot Plug	[Disable]	
Configure as eSATA	[Disable]	
Spin Up Device	[Disable]	
sSATA Device Type	[Hard Disk Drive]	
SATA Topology	[Unknown]	
ssATA Port 4	[Not Installed]	
Port 4	[Enable]	
Hot Plug	[Disable]	
Configure as eSATA	[Disable]	
Spin Up Device	[Disable]	
sSATA Device Type	[Hard Disk Drive]	
SATA Topology	[Unknown]	
ssATA Port 5	[Not Installed]	
Port 5	[Enable]	
Hot Plug	[Disable]	
Configure as eSATA	[Disable]	
Spin Up Device	[Disable]	
sSATA Device Type	[Hard Disk Drive]	
SATA Topology	[Unknown]	

Ver. 2.21.1277 Copyright (C) 2020 American Megatrends International, LLC.

Feature	Options	Description
SATA Controller	Disabled Enabled	Enables or disables SATA Controller
Configure SATA as	AHCI RAID	This will configure SATA as RAID or AHCI .
Support Aggressive Link Power Management	Disabled Enabled	Enables or disables SALP
Port 0/2/3/4/5	Disabled Enabled	Enable or Disable SATA Port
Hot Plug	Disabled Enabled	Designates this port as Hot Pluggable.
Configure as eSATA	Disabled Enabled	Configures port as External SATA (eSATA)
Spin Up Device	Disabled Enabled	If enabled for any of ports Staggerred Spin Up will be performed and only the drives switch has this option enabled will spin up at boot. Otherwise all drives spin up at boot.
SATA Device Type	Hard Disk Drive Solid State Drive	Identify the SATA port is connected to Solid State Drive or Hard Disk Drive
SATA Topology	Unknown ISATA Direct Connect Flex M2	Identify the SATA Topology if it is Default or ISATA or Flex or DirectConnect or M2

Server ME Configuration

Aptio Setup - American Megatrends International, LLC.

Platform Configuration

General ME Configuration		
Oper. Firmware Version	0F:4.4.3.192	
Backup Firmware Version	N/A	
Recovery Firmware Version	0F:4.4.3.192	
ME Firmware Status #1	0x000F0255	
ME Firmware Status #2	0x8911C006	
Current State	Operational	
Error Code	No Error	
Recovery Cause	N/A	

++: Select Screen
 ↑↓: Select Item
 Enter: Select
 +/-: Change Opt.
 F1: General Help
 F2: Previous Values
 F3: Optimized Defaults
 F4: Save & Exit
 ESC: Exit

Ver. 2.21.1277 Copyright (C) 2020 American Megatrends International, LLC.

Socket Configuration

Select the "Socket Configuration" menu items from the BIOS setup screen to enter the Socket setup screen. Users can select any of the items in the left frame of the screen.

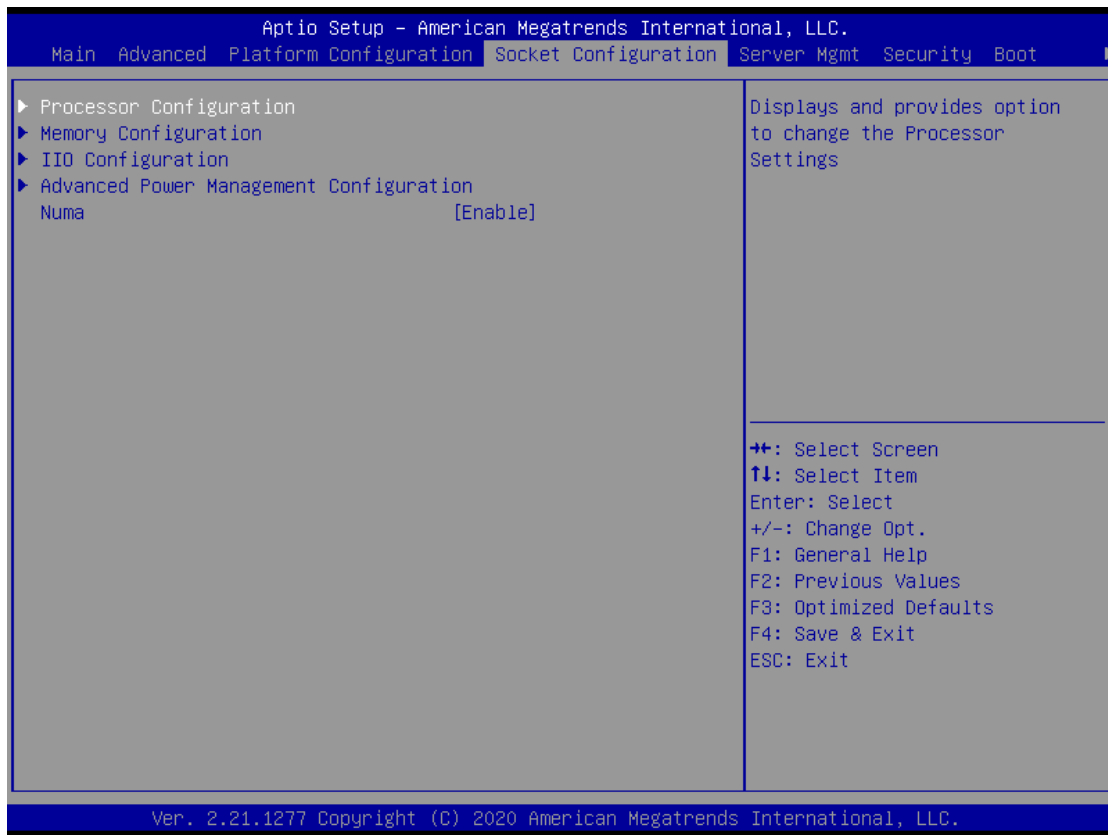

Feature	Options	Description
Processor Configuration	None	Displays and provides option to change the Processor Settings
Memory Configuration	None	Displays and provides option to change the Memory Settings
IIO Configuration	None	Displays and provides option to change the IIO Settings
Advanced Power Management Configuration	None	Displays and provides option to change the Power Management Settings
Numa	Disabled Enabled	Displays and provides option to change the Power Management Settings

Processor Configuration

Aptio Setup - AMI

Socket Configuration

<p>Processor Configuration</p> <p>-----</p> <p>---</p> <p>▶ Per-Socket Configuration</p> <p>Processor BSP Revision 606A6 - ICX D0</p> <p>Processor Socket Socket 0</p> <p>Processor ID 000606A6*</p> <p>Processor Frequency 2.400GHZ</p> <p>Processor Max Ratio 18H</p> <p>Processor Min Ratio 08H</p> <p>Microcode Revision 8D000180</p> <p>L1 Cache RAM(Per Core) 80KB</p> <p>L2 Cache RAM(Per Core) 1280KB</p> <p>L3 Cache RAM(Per Package) 55296KB</p> <p>Processor 0 Version Intel(R) Xeon(R) Platin um 8351N CPU @@ @@</p>	<p>▲ Change Per-Socket Settings</p> <hr/> <p>↔: Select Screen</p> <p>↑↓: Select Item</p> <p>Enter: Select</p> <p>+/-: Change Opt.</p> <p>F1: General Help</p> <p>F2: Previous Values</p> <p>F3: Optimized Defaults</p> <p>F4: Save & Exit</p> <p>▼ ESC: Exit</p>
--	--

Version 2.21.1278 Copyright (C) 2021 AMI

AB

Aptio Setup - AMI

Socket Configuration

<p>Microcode Revision 8D000180</p> <p>L1 Cache RAM(Per Core) 80KB</p> <p>L2 Cache RAM(Per Core) 1280KB</p> <p>L3 Cache RAM(Per Package) 55296KB</p> <p>Processor 0 Version Intel(R) Xeon(R) Platin um 8351N CPU @@ @@</p> <p>Hyper-Threading [ALL] [Enable]</p> <p>Machine Check [Enable]</p> <p>Hardware Prefetcher [Enable]</p> <p>Adjacent Cache Prefetch [Enable]</p> <p>Extended APIC [Disable]</p> <p>Enable Intel(R) TXT VMX [Disable]</p> <p>Enable SMX [Disable]</p> <p>AES-NI [Enable]</p>	<p>▲ Enable/disable AES-NI support</p> <hr/> <p>↔: Select Screen</p> <p>↑↓: Select Item</p> <p>Enter: Select</p> <p>+/-: Change Opt.</p> <p>F1: General Help</p> <p>F2: Previous Values</p> <p>F3: Optimized Defaults</p> <p>F4: Save & Exit</p> <p>▼ ESC: Exit</p>
---	---

Version 2.21.1278 Copyright (C) 2021 AMI

B4

Feature	Options	Description
Hyper-Threading [ALL]	Disabled Enabled	Enables Hyper Threading (Software Method to Enable/Disable Logical Processor threads.
Machine Check	Disabled Enabled	Enable or Disable the Machine Check
Hardware Prefetcher	Disabled Enabled	= MLC Streamer Prefetcher (MSR 1A4h Bit[0])
Adjacent Cache Prefetcher	Disabled Enabled	= MLC Spatial Prefetcher (MSR 1A4h Bit[1])
Extended APIC	Disabled Enabled	Enables or disables extended APIC support
Enable Intel® TXT	Disabled Enabled	Enables Intel(R) TXT
VMX	Disabled Enabled	Enables the Vanderpool Technology, which takes effect after reboot.
Enable SMX	Disabled Enabled	Enables Safer Mode Extensions
AES-NI	Disabled Enabled	Enables or disables AES-NI support

Per-Socket Configuration

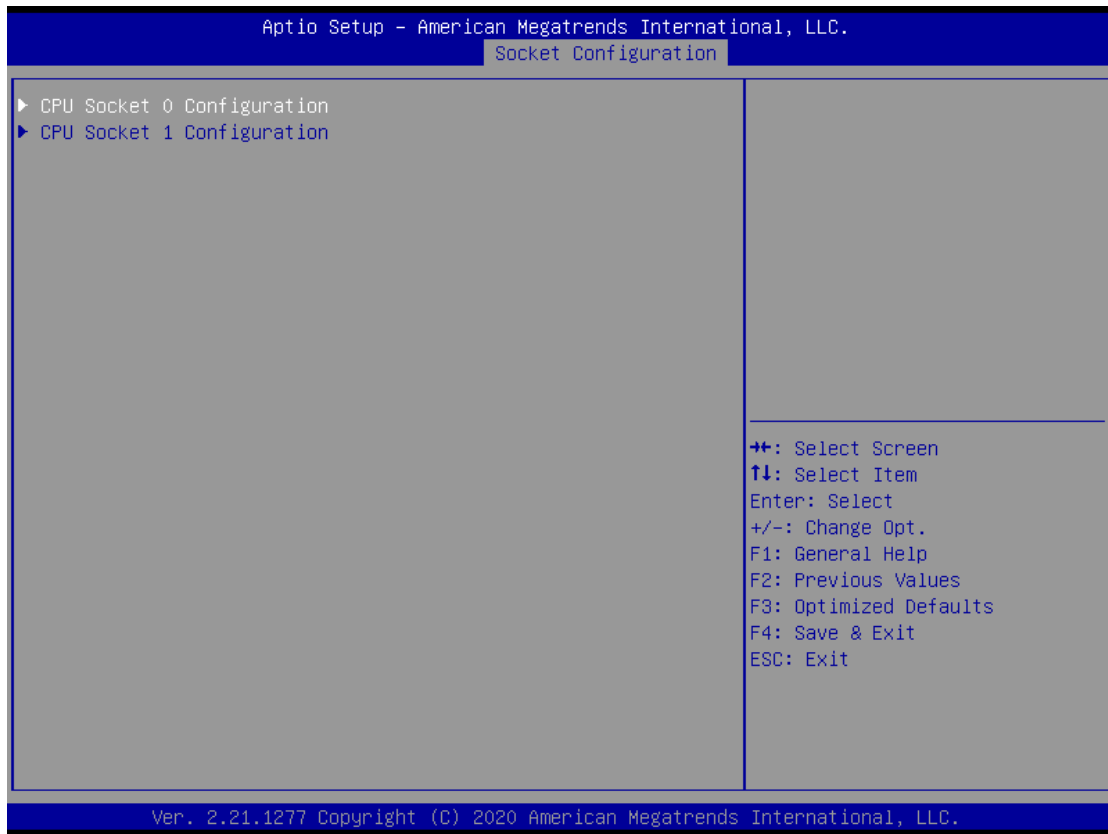

Feature	Options	Description
CPU Socket0 Configuration	None	None

CPU Socket0 Configuration

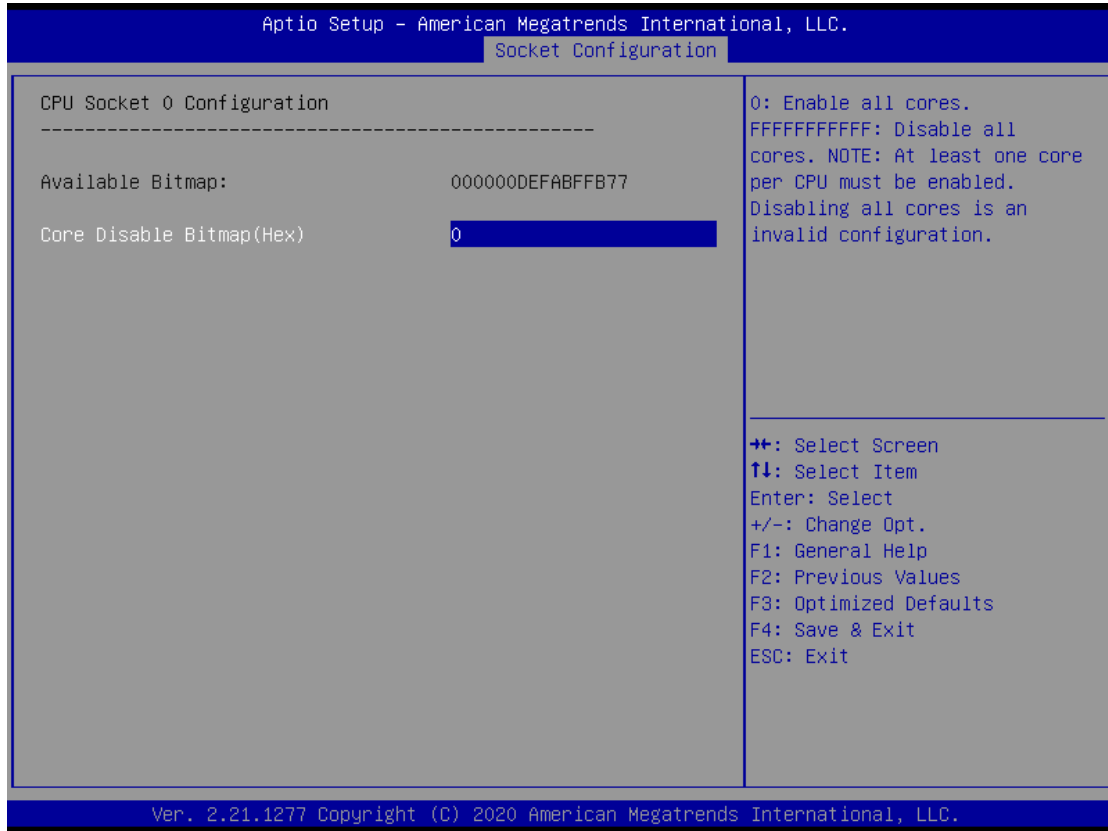

Feature	Options	Description
Core Disable Bitmap(Hex)	0	0: Enable all cores. FFFFFFFFF: Disable all cores least one core per CPU must be enabled. Disabling all cores is an invalid configuration.

Memory Configuration

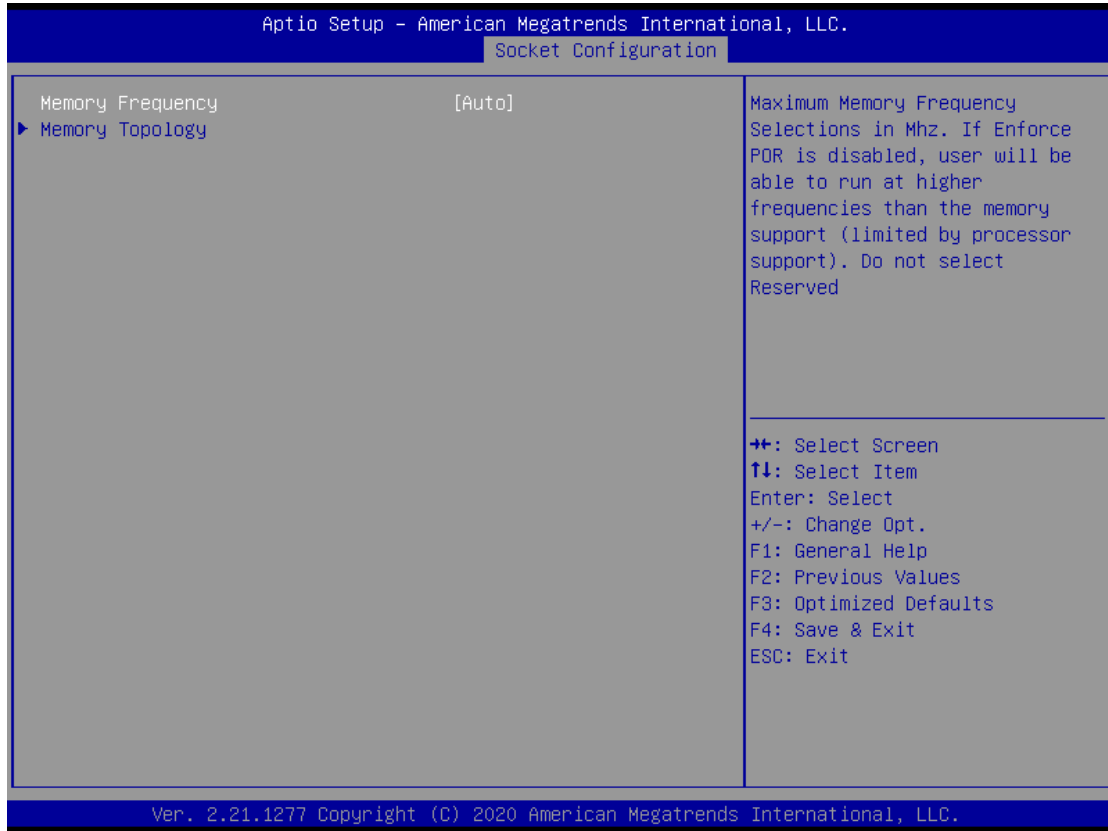

Feature	Options	Description
Memory Frequency	Auto	Maximum Memory Frequency Selections in Mhz. Do not select Reserved
	1200	
	1333	
	1400	
	1600	
	1800	
	1866	
	2000	
	2133	
	2200	
	2400	
	2600	
	2666	
	2800	
	2933	
	3000	
3200		
3400-OvrClk		
3466-OvrClk		
3600-OvrClk		
3733-OvrClk		

	3800-OvrClk 4000-OvrClk 4200-OvrClk 4266-OvrClk 4400-OvrClk 4800-OvrClk	
Memory Topology	None	Displays memory topology with Dimm population information

I/O Configuration

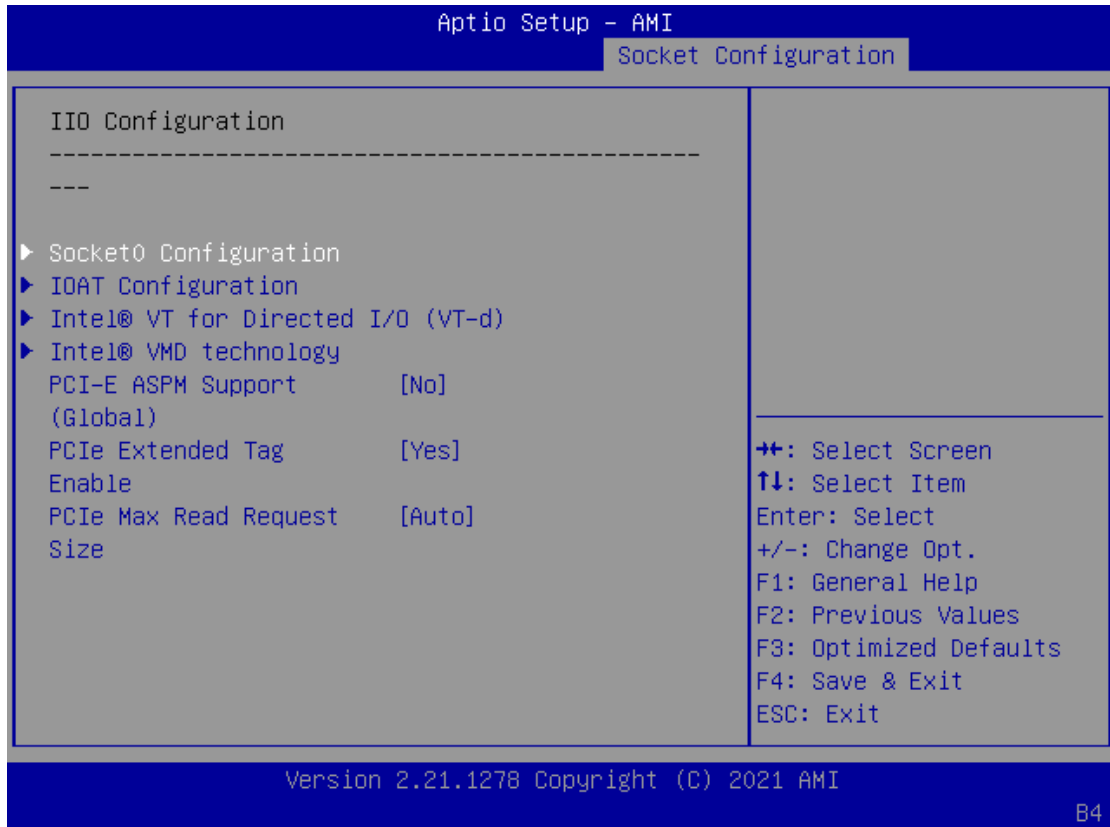

Feature	Options	Description
Socket0 Configuration	None	Socket0 Configuration
IOAT Configuration	None	IOAT Configuration
Intel® VT for Directed I/O (VT-d)	None	Intel® VT for Directed I/O (VT-d)
PCI-E ASPM Support (Global)	No Per-Port L1 Only	PCI-E ASPM Support (Global)
PCIe Extended Tag Enable	Auto No Yes	PCIe Extended Tag Enable
PCIe Max Read Request Size	Auto 128B 256B 512B 1024B 2048B 4096B	PCIe Max Read Request Size

Socket0 Configuration

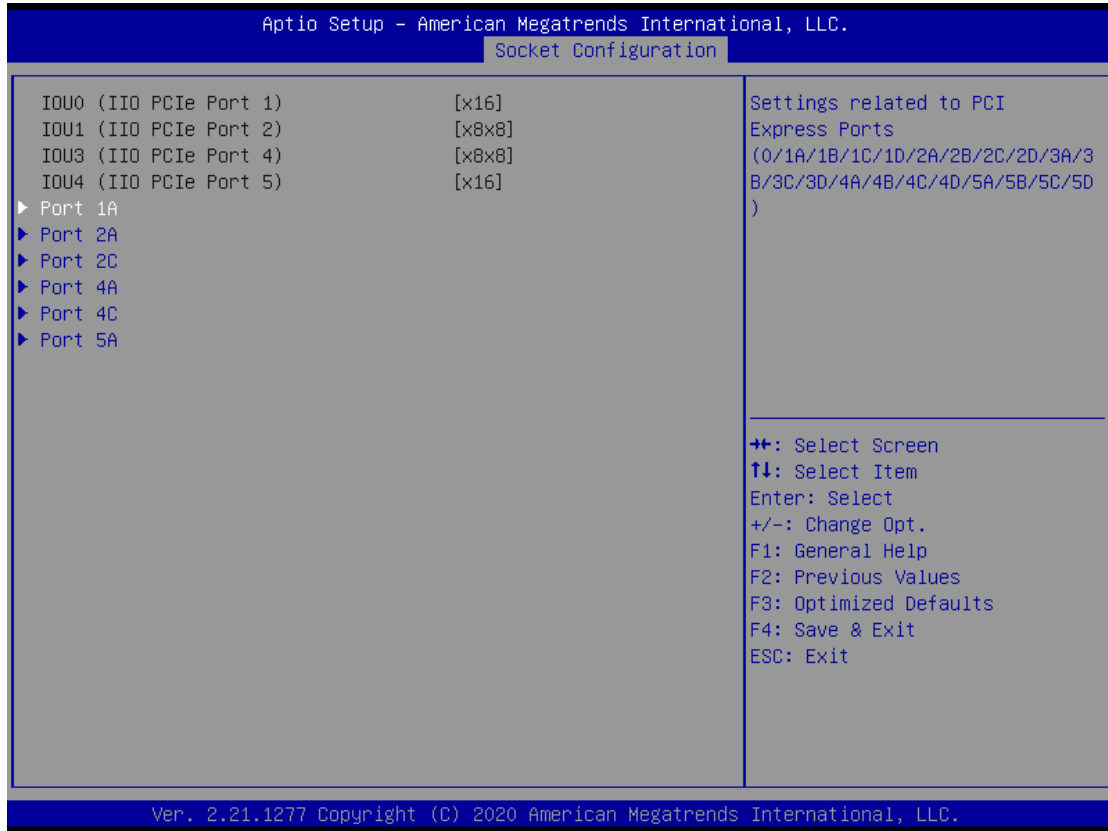

Feature	Options	Description
Socket 0 Port 1A	None	Settings related to PCI Express Port 1A
Socket 0 Port 2A	None	Settings related to PCI Express Port 2A
Socket 0 Port 2C	None	Settings related to PCI Express Port 2C
Socket 0 Port 4A	None	Settings related to PCI Express Port 4A
Socket 0 Port 4C	None	Settings related to PCI Express Port 4C
Socket 0 Port 5A	None	Settings related to PCI Express Port 5A

IOAT Configuration

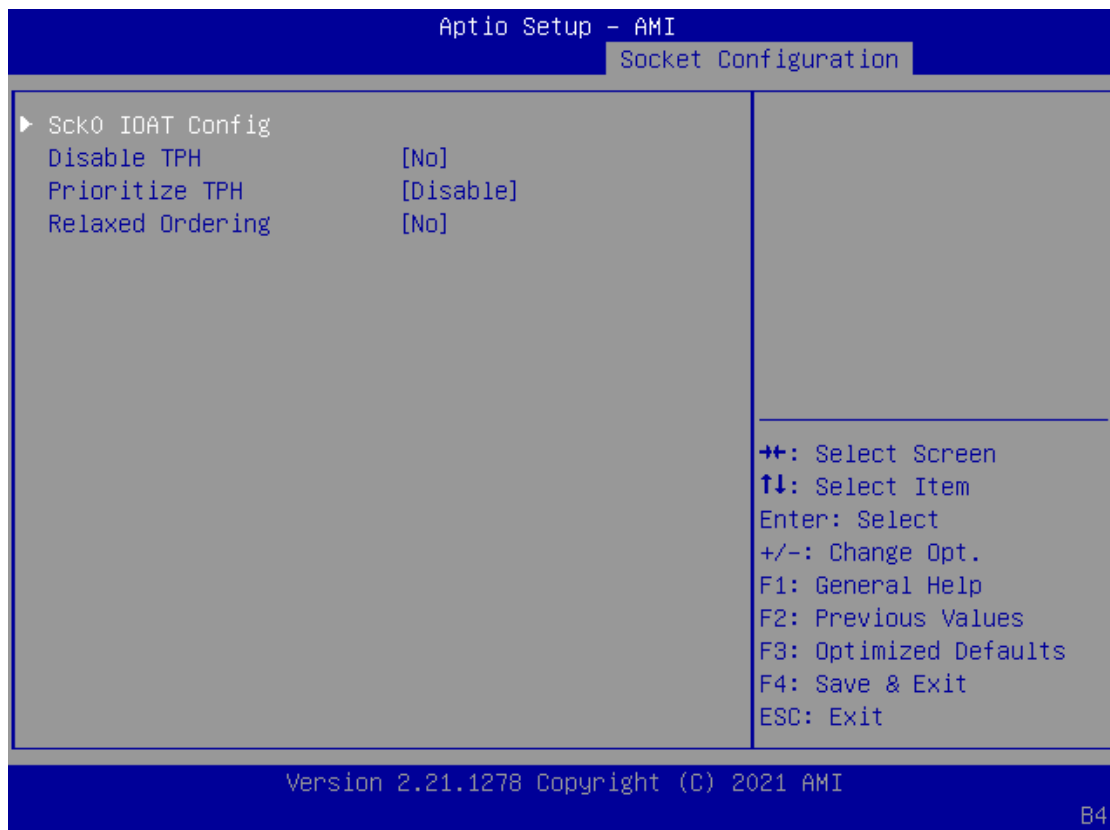

Feature	Options	Description
Sck0 IOAT Config	None	None
Disable TPH	No Yes	TLP Processing Hint disable
Prioritize TPH	Disabled Enabled	Prioritize TPH
Relaxed Ordering	No Yes	Relaxed Ordering Enable/Disable

Intel® VT for Directed I/O (VT-d)

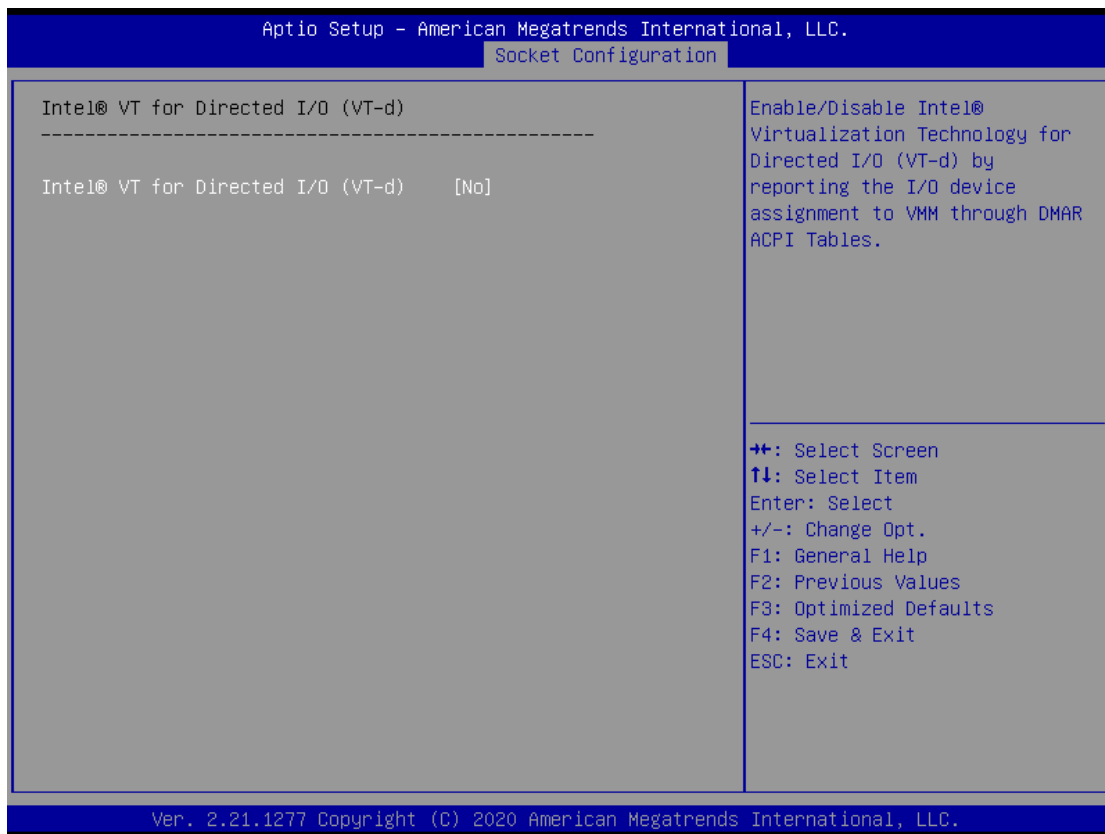

Feature	Options	Description
Intel® VT for Directed I/O (VT-d)	No Yes	Press <Enter> to bring up the Intel® VT for Directed I/O (VT-d) Configuration menu.

Advanced Power Management Configuration

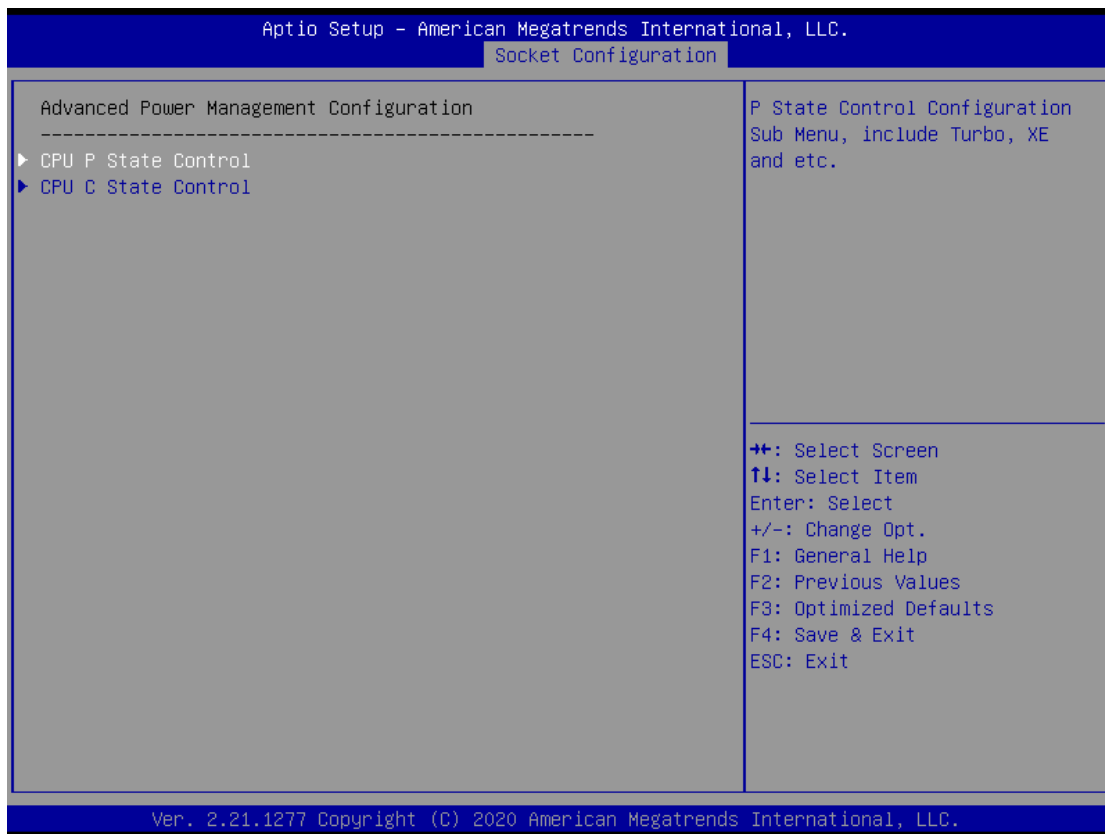

Feature	Options	Description
CPU P State Control	None	P State Control Configuration Sub Menu, include Turbo, XE and etc.
CPU C State Control	None	CPU C State setting

CPU P State Control

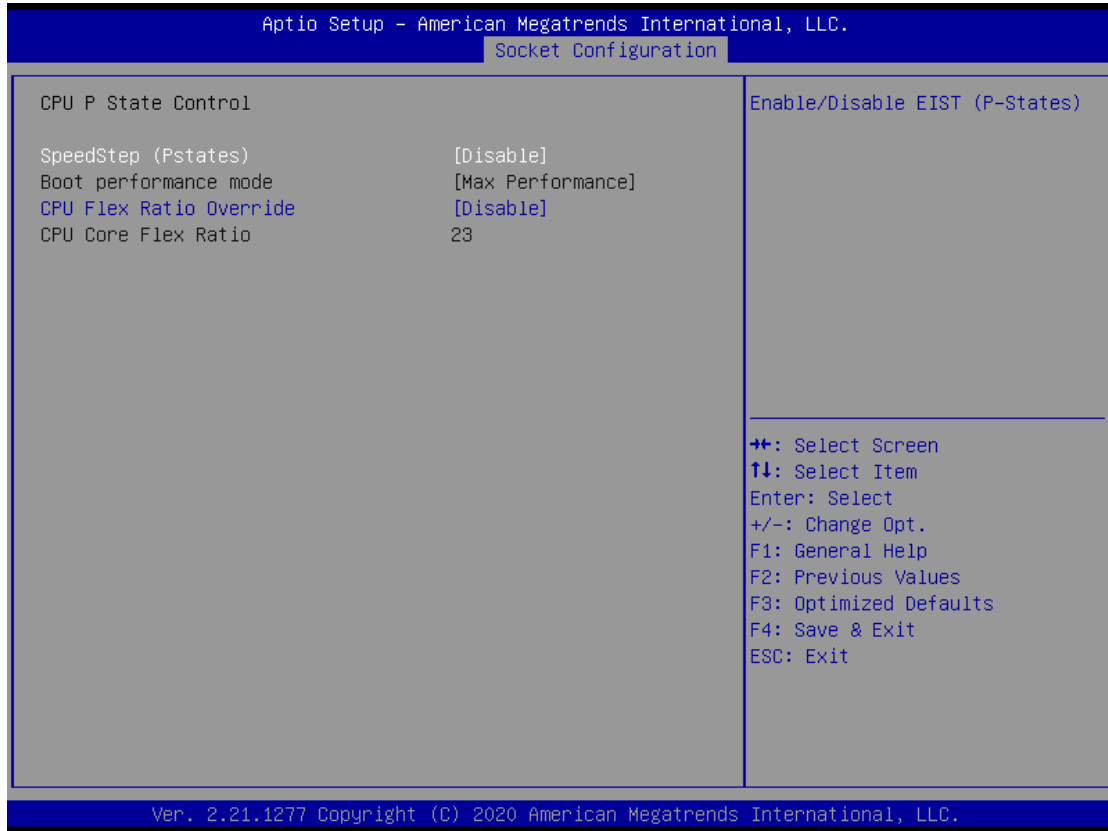

Feature	Options	Description
SpeedStep(Pstates)	Disabled Enabled	Enables or disables EIST (P-States)
Boot performance mode	Max Performance Max Efficient Set by Intel Node Manager	Select the performance state that the BIOS will set before OS hand off.
CPU Flex Ratio Override	Disabled Enabled	Enable/Disable CPU Flex Ratio Programming
CPU Core Flex Ratio	23	Non-Turbo Mode Processor Core Ratio Multiplier

CPU C State Control

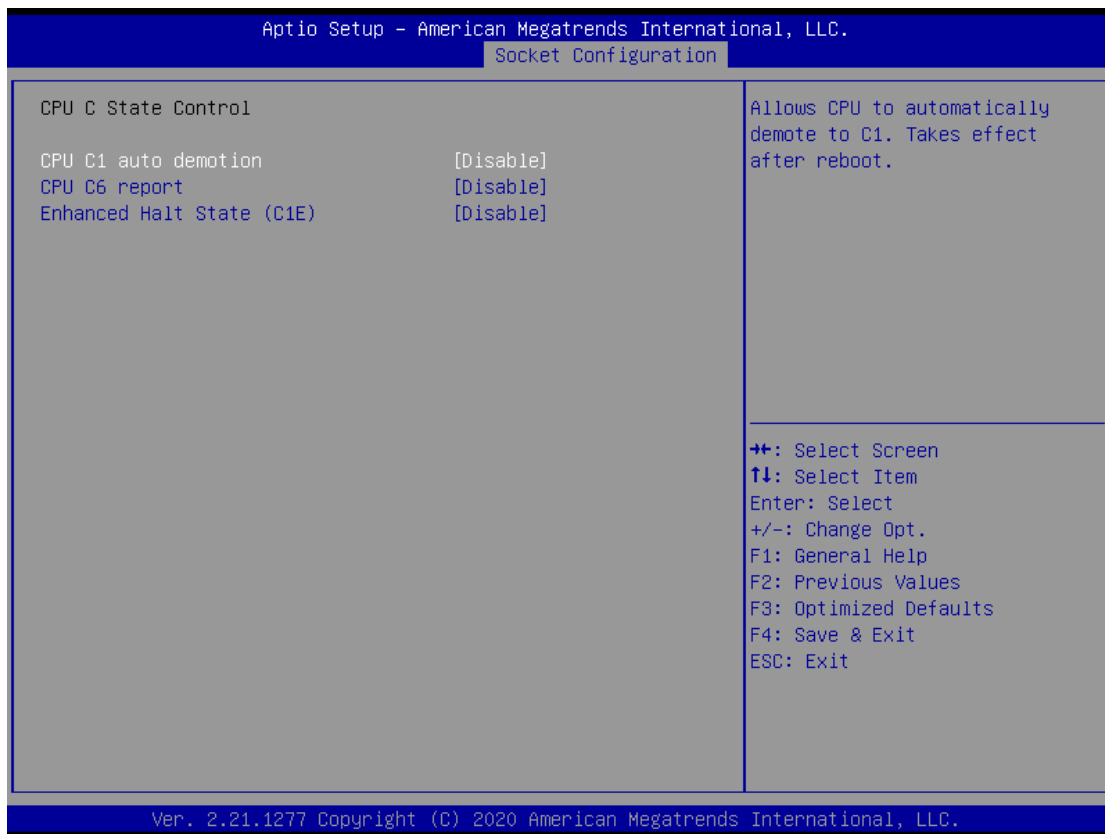

Feature	Options	Description
CPU C1 auto demotion	Disabled Enabled	Autonomous Core C-State Control
CPU C6 report	Disabled Enabled	Enables or disables CPU C6(ACPI C3) report to OS
Enhanced Halt State (C1E)	Disabled Enabled	Core C1E auto promotion Control. Takes effect after reboot.

Server Mgmt

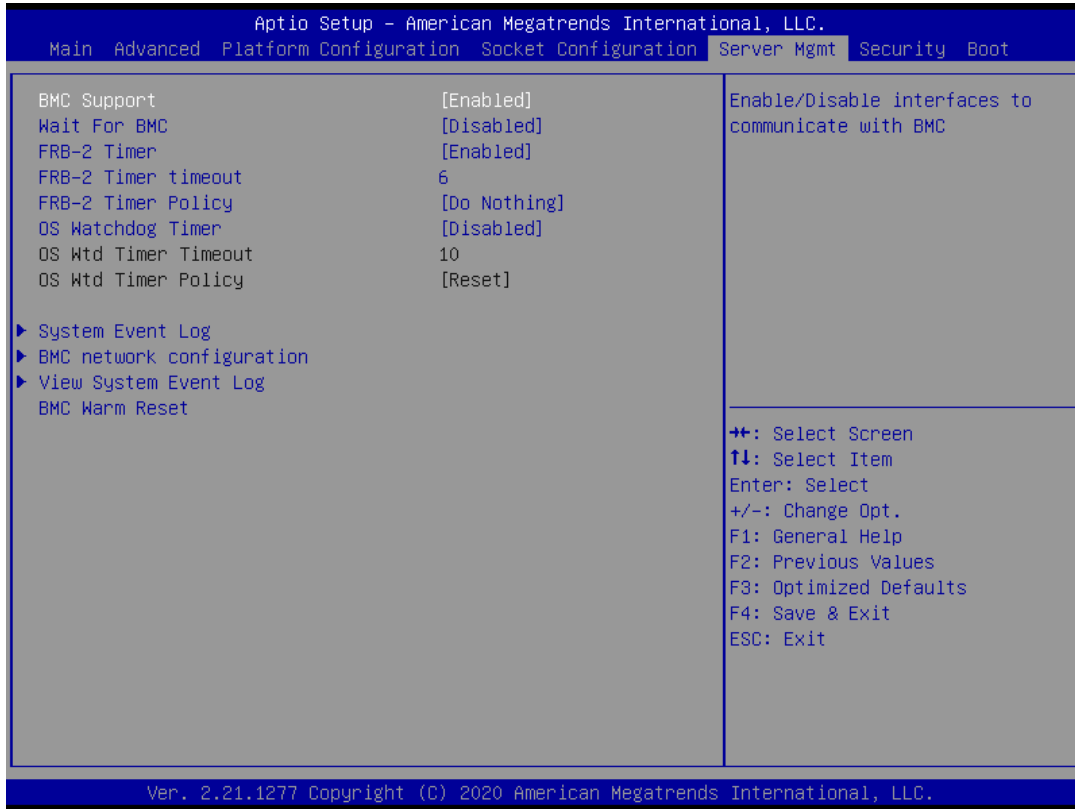

Feature	Options	Description
BMC Support	Enabled Disabled	Enable or disables interfaces to communicate with BMC.
Wait For BMC	Enabled Disabled	Wait For BMC response for specified time out. In PILOTII, BMC starts at the same time when BIOS starts during AC power ON. It takes around 30 seconds to initialize Host to BMC interfaces.
FRB-2 Timer	Enabled Disabled	Enables or disables FRB-2 timer (POST timer).
FRB-2 Timer timeout	3 minutes 4 minutes 5 minutes 6 minutes	Enter value Between 3 to 6 min for FRB-2 Timer Expiration value.
FRB-2 Timer Policy	Do Nothing Reset Power Down Power Cycle	Configure how the system should respond if the FRB-2 Timer expires. Not available if FRB-2 Timer is disabled.
OS Watchdog Timer	Enabled Disabled	If enabled, it starts a BIOS timer which can only be shut off by Management Software after the OS loads. It also helps verify that the OS is successfully loaded or follows the OS Boot Watchdog Timer policy.

OS Wtd Timer Timeout	5 minutes 10 minutes 15 minutes 20 minutes	Configure the length of the OS Boot Watchdog Timer. Not available if OS Boot Watchdog Timer is disabled.
OS Wtd Timer Policy	Do Nothing Reset Power Down Power Cycle	Configure how the system should respond if the OS Boot Watchdog Timer expires. Not available if OS Boot Watchdog Timer is disabled.
System Event Log	NA	Press <Enter> to change the SEL event log configuration.
BMC network configuration	NA	Configure BMC network parameters.
View System Event Log	NA	Press <Enter> to view the System Event Log Records.
BMC Warm Reset	NA	Press <Enter> to do Warm Reset BMC.

System Event Log



Feature	Options	Description
SEL Components	Disabled Enabled	Enables or disables all features of System Event Logging during boot.
Erase SEL	NO Yes, On next reset Yes, On every reset	Choose options for erasing SEL.
When SEL is Full	Do Nothing Erase Immediately Delete Oldest Record	Choose options for reactions to a full SEL.

BMC Network Configuration

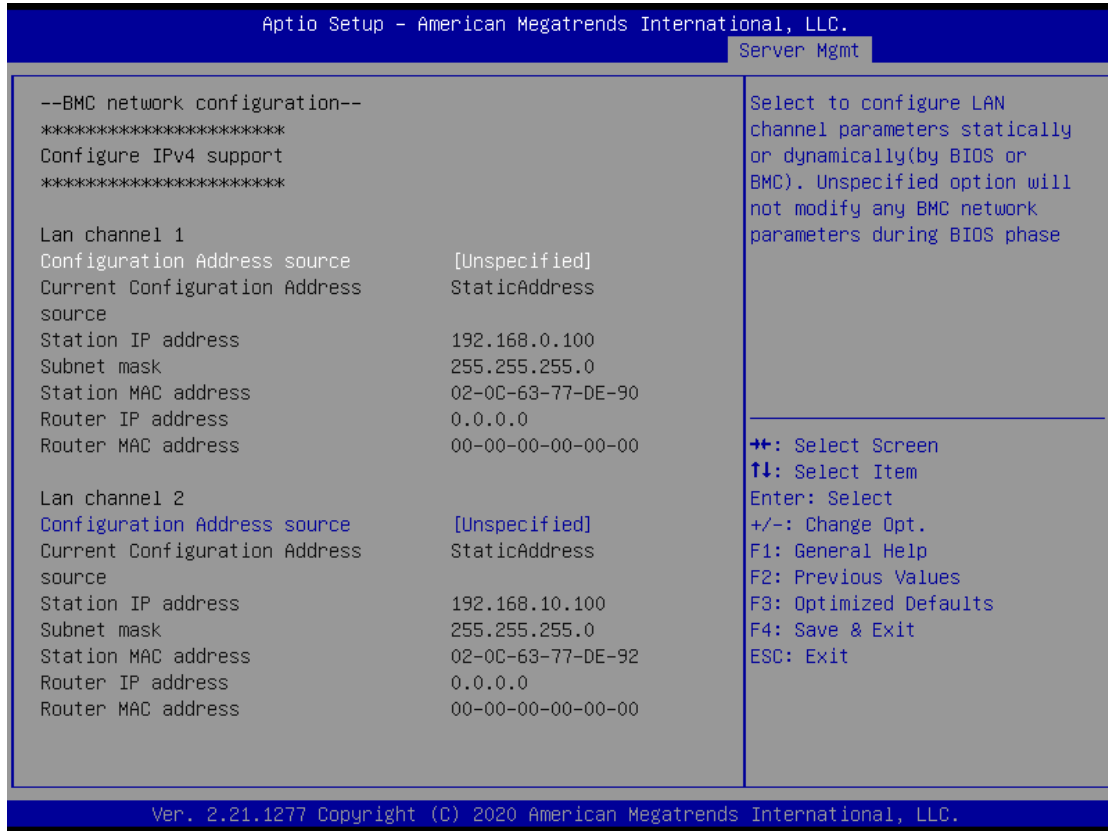

Feature	Options	Description
Configuration Address source	<p>Unspecified</p> <p>Static</p> <p>DynamicBmcDhcp</p>	Select to configure LAN channel parameters statically or dynamically (by BIOS or BMC). The unspecified option will not modify any BMC network parameters during BIOS phase.

View System Event Log

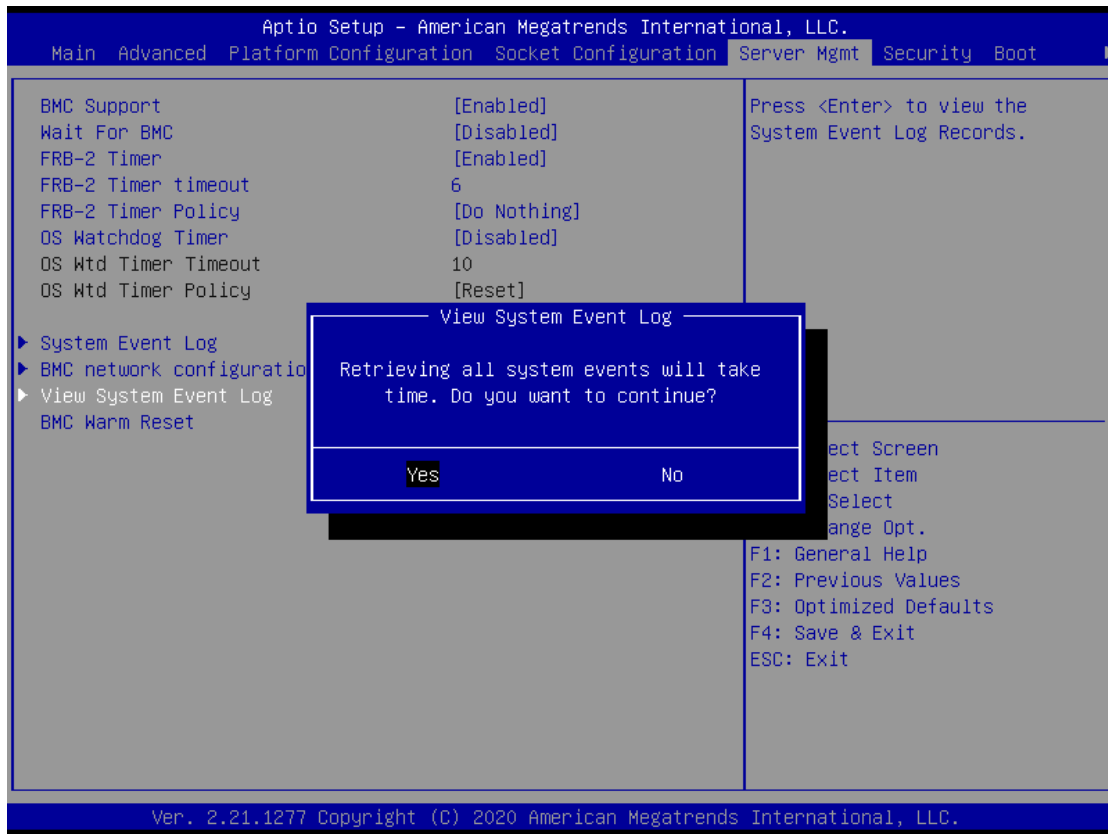

Security

Select the "Security" menu item from the BIOS setup screen to enter the Security setup screen. Users can select any of the items in the left frame of the screen.

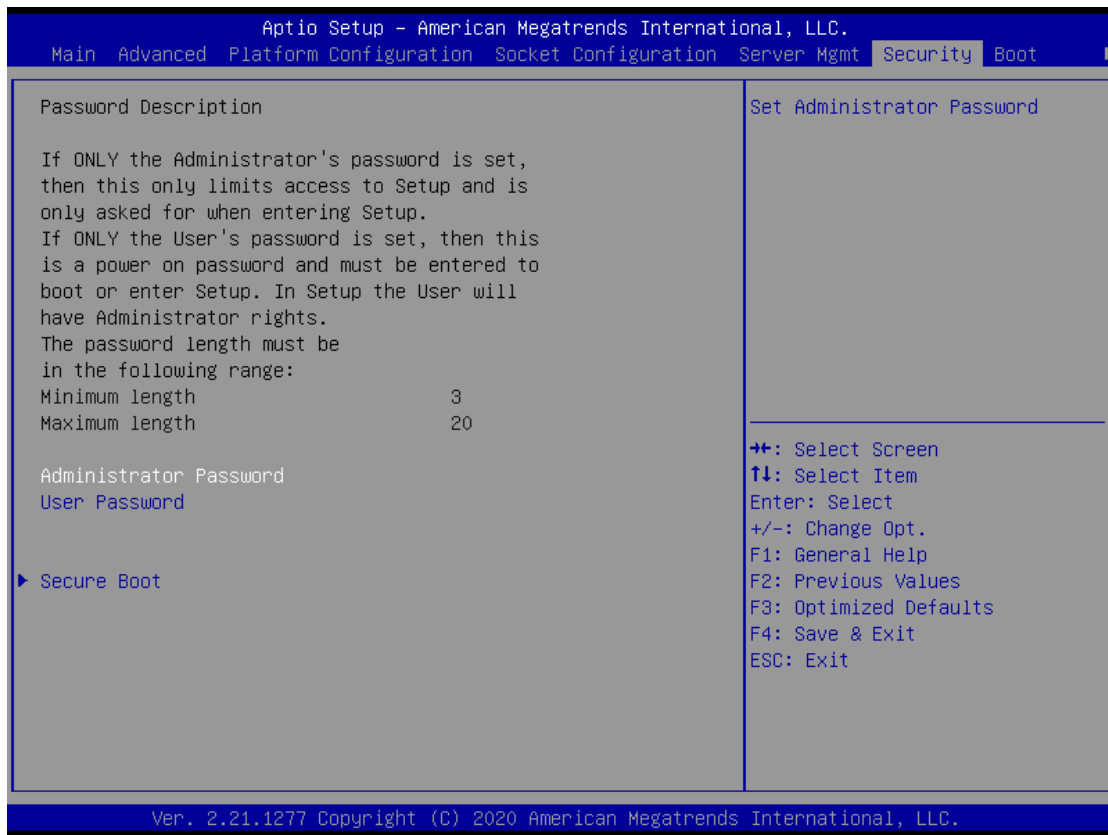

Feature	Description
Administrator Password	If ONLY the Administrator's password is set, it only limits access to Setup and is only asked for when entering Setup.
User Password	If ONLY the User's password is set, it serves as a power-on password and must be entered to boot or enter Setup. In Setup, the User will have Administrator rights.

Secure Boot



Feature	Options	Description
Secure Boot	Disabled Enabled	Secure Boot is activated when Platform Key (PK) is enrolled, System mode is User/Deployed, and CSM function is disabled.
Secure Boot Mode	Standard Custom	Secure Boot mode selector: In Custom mode, Secure Boot Variables can be configured without authentication

Key Management

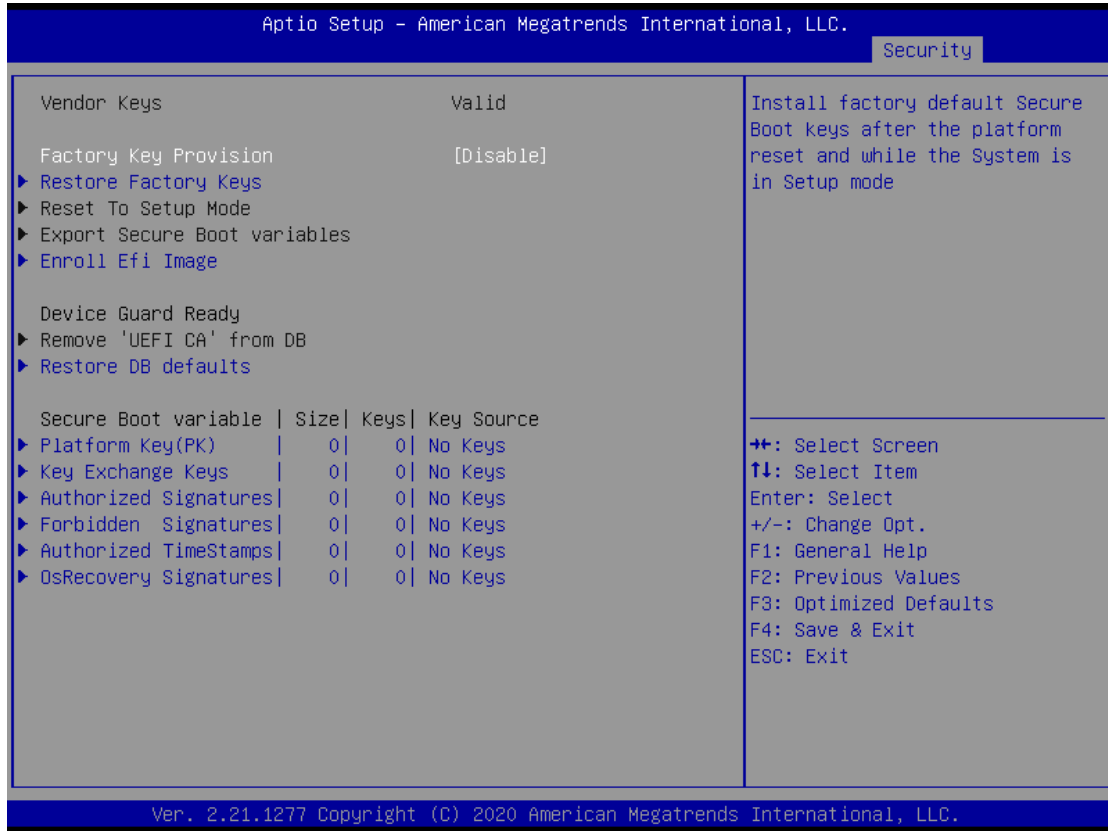

Feature	Options	Description
Factory Key Provision	Disabled Enabled	Provision factory default keys on next re-boot only when System in Setup Mode.
Restore Factory keys	None	Force System to User Mode. Configure NVRAM to contain OEM-defined factory default Secure Boot keys.
Enroll Efi Image	None	Allows the image to run in Secure Boot mode. Enroll SHA256 hash of the binary into Authorized Signature Database (db)

Boot Menu

Select the "Boot" menu item to enter the Boot setup screen. Users can select any of the items on the left frame of the screen.

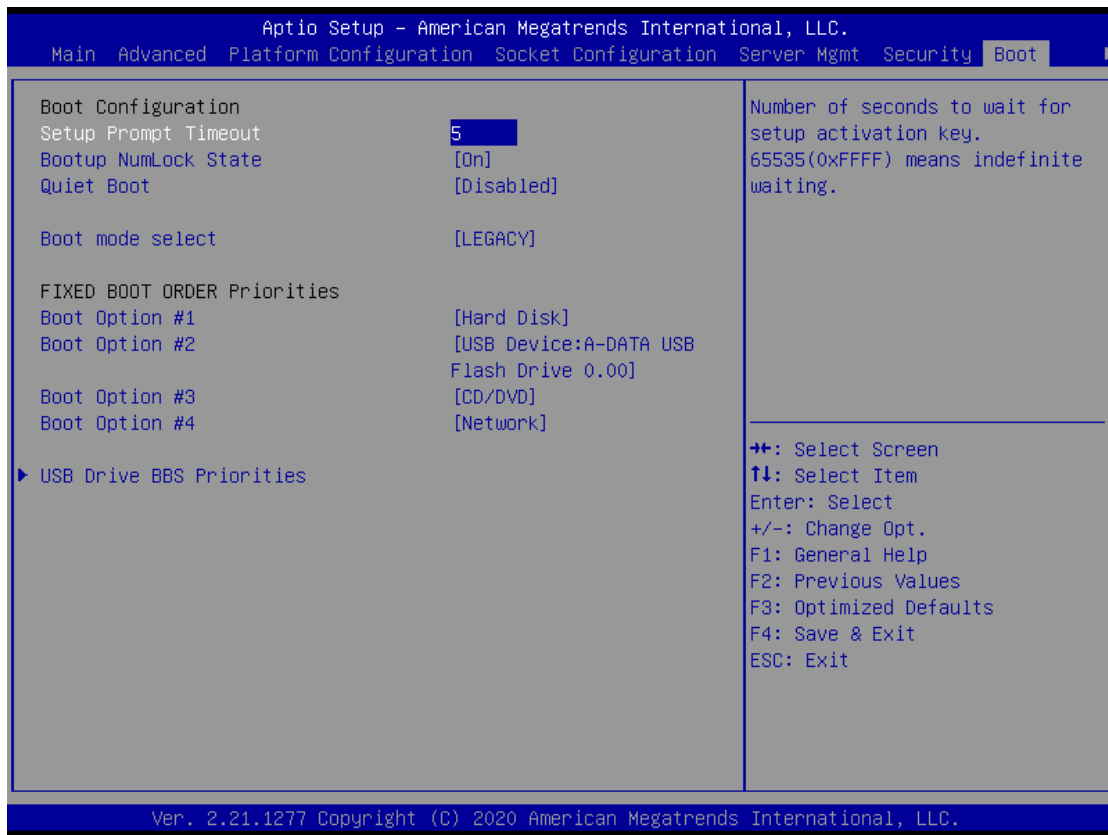

Feature	Options	Description
Setup Prompt Timeout	5	The Number of seconds to wait for setup activation key. 65535 means indefinite waiting.
BootupNumLock State	On Off	Select the keyboard NumLock state.
Quiet Boot	Disabled Enabled	Enables or disables Quiet Boot option.
Boot mode select	LEGACY UEFI DUAL	Select boot mode for LEGACY or UEFI.

- Choose boot priority from boot option group.
- Choose specifies boot device priority sequence from available Group device.

Save and Exit Menu

Select the "Save & Exit" menu to enter the Save and Exit setup screen. Users can select any of the items on the left frame of the screen.

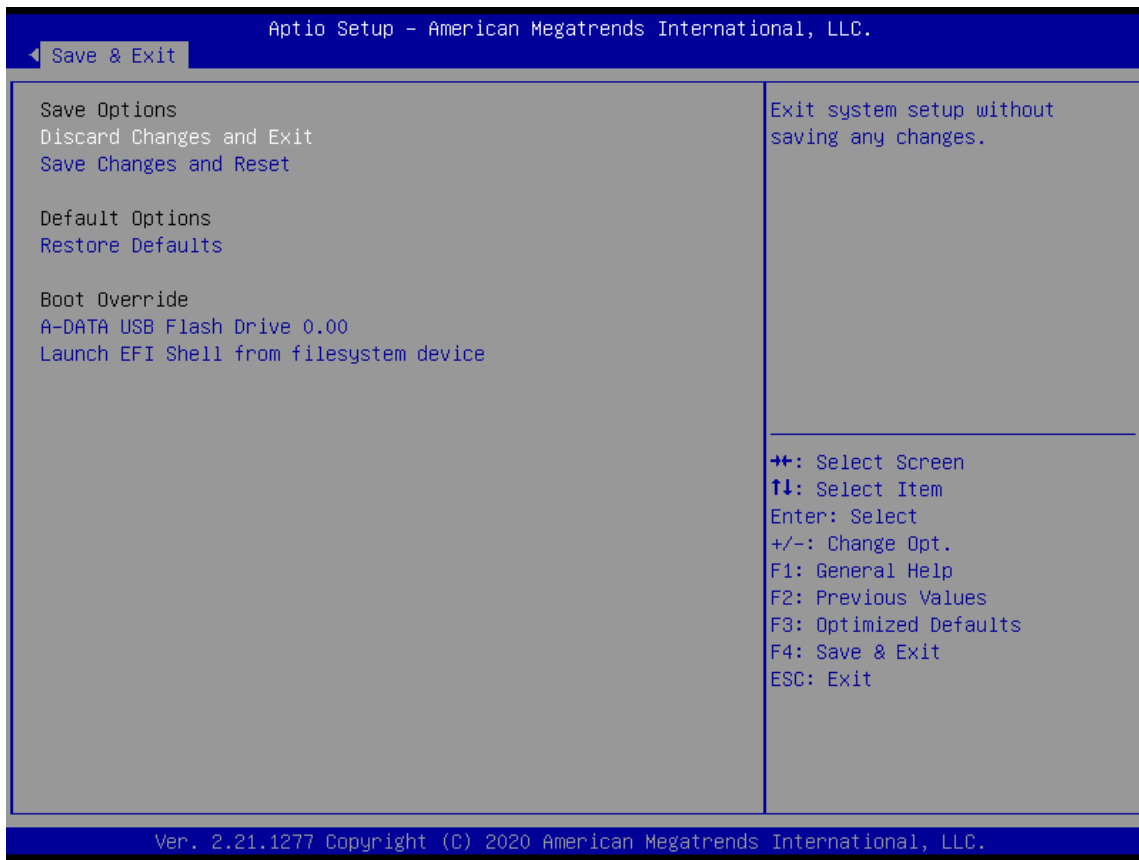

■ Discard Changes and Exit

Select this option to quit Setup without saving any modifications to the system configuration. The following window will appear after the "Discard Changes and Exit" option is selected. Select "Yes" to Discard changes and Exit Setup.

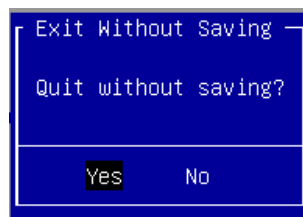

■ Save Changes and Reset

When Users have completed the system configuration changes, select this option to save the changes and reset from BIOS Setup in order for the new system configuration parameters to take effect. The following window will appear after selecting the **“Save Changes and Reset”** option is selected. Select **“Yes”** to Save Changes and reset.

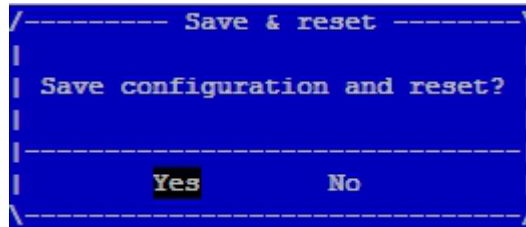

■ Restore Defaults

Restore default values for all setup options. Select **“Yes”** to load Optimized defaults.

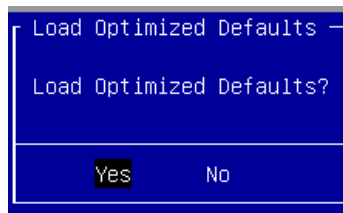

Note: The items under Boot Override were not same with image. It should depend on devices connect on system.

APPENDIX A: LED INDICATOR EXPLANATIONS

▶ System Power / Status / HDD Activity

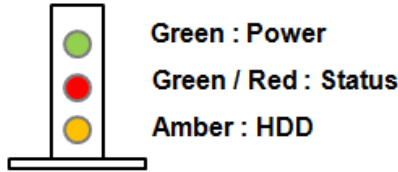

LED	COLOR ON LCM	COLOR ON BOARD	LED ACTION	DESCRIPTION
POWER	Green	Green	Steady	When system power on
	Off	Off	N/A	No power on
STATUS	Green	Green	Steady	control by GPIO
	Amber	Red	Steady	control by GPIO
	Off	Off	N/A	control by GPIO (Default) or No power on
HDD	Amber	Amber	Blinking	Blinking indicates HDD activity Include SATA / NVME
	Off	Off	N/A	No data access or No power on

▶ RJ-45 LAN LED

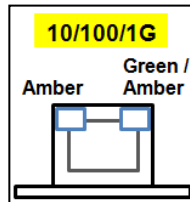

1Gb RJ-45 Define:

Speed	Amber (Active)	Green / Amber (Link)
10M	Blinking / Data access	OFF
100M	Blinking / Data access	ON (Green)
1G	Blinking / Data access	ON (Amber)

1. When cable is plug-in and network is linked. Both LED will be bright. The behavior is as defined.
2. Without the Cable plug-in, the LED should be off
3. If LAN Driver controls the LED, the behavior will follow the driver

APPENDIX B: TERMS AND CONDITIONS

Warranty Policy

1. All products are under warranty against defects in materials and workmanship for a period of one year from the date of purchase.
2. The buyer will bear the return freight charges for goods returned for repair within the warranty period; whereas the manufacturer will bear the after-service freight charges for goods returned to the user.
3. The buyer will pay for repair (for replaced components plus service time) and transportation charges (both ways) for items after the expiration of the warranty period.
4. If the RMA Service Request Form does not meet the stated requirement as listed on "RMA Service," RMA goods will be returned at customer's expense.
5. The following conditions are excluded from this warranty:
 - ▶ Improper or inadequate maintenance by the customer
 - ▶ Unauthorized modification, misuse, or reversed engineering of the product
 - ▶ Operation outside of the environmental specifications for the product.

RMA Service

Requesting an RMA#

1. To obtain an RMA number, simply fill out and fax the "RMA Request Form" to your supplier.
2. The customer is required to fill out the problem code as listed. If your problem is not among the codes listed, please write the symptom description in the remarks box.
3. Ship the defective unit(s) on freight prepaid terms. Use the original packing materials when possible.
4. Mark the RMA# clearly on the box.



Note

Customer is responsible for shipping damage(s) resulting from inadequate/loose packing of the defective unit(s). All RMA# are valid for 30 days only; RMA goods received after the effective RMA# period will be rejected.

RMA Service Request Form

When requesting RMA service, please fill out the following form. Without this form enclosed, your RMA cannot be processed.

RMA No:	Reasons to Return: <input type="checkbox"/> Repair (Please describe failure details) <input type="checkbox"/> Testing Purpose
Company:	Contact Person:
Phone No.:	Purchased Date:
Fax No.:	Apply Date:
Return Shipping Address: _____	
Shipping by: <input type="checkbox"/> Air Freight <input type="checkbox"/> Sea <input type="checkbox"/> Express: _____ <input type="checkbox"/> Others: _____	

Item	GP	Model Name	Serial Number	Configuration

Item	Problem Code	Failure Status

***Problem Code:**

- | | | | |
|------------------------|------------------------------|--------------------|--------------------------|
| 01: D.O.A. | 07: BIOS Problem | 13: SCSI | 19: DIO |
| 02: Second Time R.M.A. | 08: Keyboard Controller Fail | 14: LPT Port | 20: Buzzer |
| 03: CMOS Data Lost | 09: Cache RMA Problem | 15: PS2 | 21: Shut Down |
| 04: FDC Fail | 10: Memory Socket Bad | 16: LAN | 22: Panel Fail |
| 05: HDC Fail | 11: Hang Up Software | 17: COM Port | 23: CRT Fail |
| 06: Bad Slot | 12: Appearance Damage | 18: Watchdog Timer | 24: Others (Pls specify) |

Requested by

Confirmed by supplier

Authorized Signature / Date

Authorized Signature / Date