

- ▶ Substation Cyber Security with IEC61850
- ▶ Oil & Gas Cyber Security
- ▶ Industrial Cyber Security
- ▶ Solar Power Monitoring
- ▶ Industrial Firewall for Energy Sector
- ▶ Effective Solar PV Monitoring
- ▶ IEC 61850 Substation Automation Gateway

**Lanner**

# Power and Energy

## Solution Brief

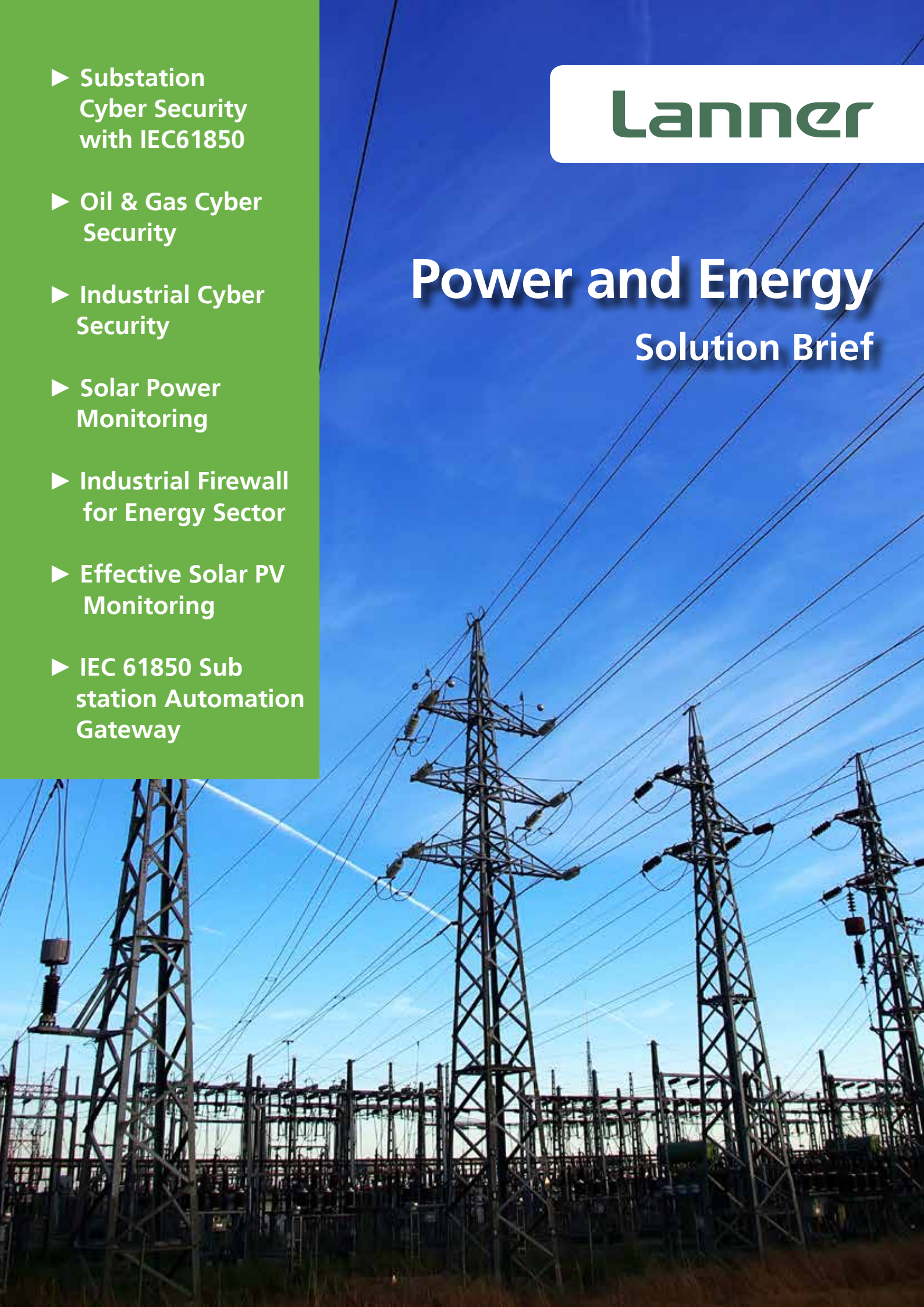

# Protecting Substations from Cyber Threats with IEC61850 Compliant Communication Platform

## Background

Since the cyber attack of Ukraine's power grids in December, 2015, it is clear that traditional ICS, SCADA and off-the-shelf operating systems in substation present imminent vulnerabilities for cyber attack. As the OT networks in critical infrastructures and IT-based control layer devices are more and more interconnected, there have been more loopholes exposed to cyber intruders. Since the energy infrastructures are highly critical to the economic well-beings of the societies, a successfully penetrated attack would cause devastating effects to the enterprises, the government and the people. Therefore, it is necessary to implement an industrial-grade network gateway to secure the industrial communication networks and protocols as most cyber attacks come from this channel.

## Lanner Solution

Designing a Communication Platform for Substation Cyber Security

An industrial cyber security solution provider headquartered in Beijing, China, came to Lanner for designing and developing a new hardware platform tailored for cyber-security implications for IT/OT convergence in the power grids, power plants and substations. The required communication platform must fulfill several technological prerequisites in order to work in the power-generation sites.

- EMC certifications required for power sectors
- Comply with NSAS (Network Security Audit System)
- IEC 61850-3 certified for energy and critical assets
- High-performance CPU to process huge data volume
- Multiple Ethernet interfaces for optimal connections under harsh environments
- Scalability to adapt into demanding environments
- Wide operating temperature

## Key Application

- Power SCADA Automation Platform
- Automation Platform for Substation
- IED Communication Gateway

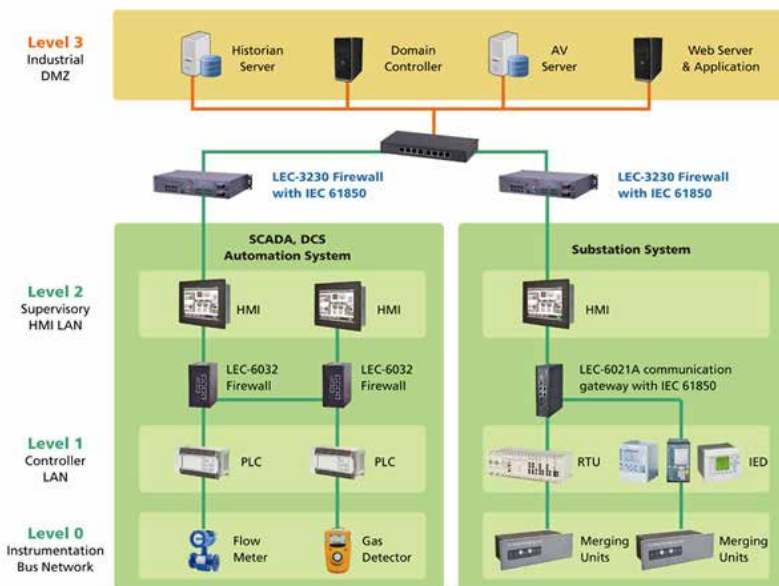

# Protecting Substations from Cyber Threats with IEC61850 Compliant Communication Platform



## IEC61850 Certified Network Security Gateway

With the above-mentioned technological requirements in mind, Lanner introduced LEC-3230, an IEC-61850-3 certified 2U rackmount industrial gateway empowered by Intel® Core™ i7-3517UE CPU. The fanless system supports wide operating temperature (-20 to 55°C) and has passed EMC and NSAS tests required for deployments within critical assets.

LEC-3230 is empowered by high-performance Intel® Core™ i7-3517UE CPU to process huge volume of data and perform various cyber security applications in an efficient manner. The system supports rich Ethernet configurations, with 4 + 4 GbE or 4 + 8 GbE LAN ports, which support 10/100/1000 Gigabits transmission specifications. The design of rich, scalable Ethernet ports allows multi-purposes of cyber security functions including DPI (Deep Packet Inspection), IPS (Intrusion Prevention System), web/protocol filtering, data encryptions, DDoS prevention and more.

Regarding future-proof design for connectivity scalability, LEC-3230 also comes with options of add-on, expandable I/O module cards, including:

- 4 x 10/100/1000 RJ45 GbE
- 8 x 10/100/1000Mbps RJ45 GbE
- 2 x RJ45 + 2x fiber GbE

### Featured Products

**LEC-3230**



Part Number	LEK-2G2F: 4x Gigabit Ethernet module	LEK-EH1: 4x Gigabit Ethernet module	LEK-8GE: 8x Gigabit Ethernet module
Feature	<ul style="list-style-type: none"> <li>• Intel i210T/i210ES</li> <li>• 2 x RJ45, 2 x SFP</li> <li>• Windows 7/Linux driver</li> </ul>	<ul style="list-style-type: none"> <li>• Intel 82583V</li> <li>• 4 x RJ45</li> <li>• Windows/Linux driver</li> </ul>	<ul style="list-style-type: none"> <li>• Intel 82583V</li> <li>• 8 x RJ45</li> <li>• Windows/Linux driver</li> </ul>

### IEC 61850-3 certified 2U Rackmount Security Appliance with flexible I/O Module Design

- Intel Core i7-3217UE processor with HM65 chipset
- DDR3 memory, maximum capacity is 8 GB
- Fanless design with corrugated aluminum
- IEC 61850-3 & IEEE 1613 compliant
- Wide temperature range (-20~55°C)
- Rich and expandable modules for flexible Ethernet connectivity
- ESD and surge protection on Serial COM ports
- Intel GbE LAN ports with magnetic isolation protection



# Integrating Multi-Layer Architectures to Mitigate Cyber Vulnerabilities in Oil and Gas Sectors

## Background

Nowadays, utility productions, such as oilfield, petroleum refinery, and offshore gas drilling, have become more and more digitalized and connected. Devices deployed such as PLCs, HMIs, SCADA, sensors and embedded computing systems are inter-connected operational technologies (OT) in order to optimize automation and productions. Though digitalization and interconnections of OT devices have increased productivity and outputs for the oil and gas industry, the door is opened to cyber attacks at the same time. As a matter of fact, the numbers of cyber attacks to utility production industries have been rising continuously. According to researches, over 60% utility companies have encountered at least one attack in past years and petroleum industry is listed as one of the most targeted industries for cyber attacks.

## Lanner Solution

Since oil and gas are two major utilities for daily lives, critical assets like refineries, production plants, and installation sites are high-profile targets for hackers. If these OT environments are under attack, serious consequences include plant shutdown, production failure, and inception of confidential data, which will eventually sabotage national economies and create panic in public. Therefore, when OT devices are connected, we must ensure secured communication throughout the entire ICS network traffic and protocols.

The OT protocols of traditional ICS and SCADA are vulnerable to cyber threats, as these protocols are usually left unprotected and open. This vulnerability attracts hackers to manipulate oil and gas refineries and plants by introducing malwares through different access points of control networks.

In order to protect the interconnected devices and the network protocols, critical asset owners shall implement multi-layer network security platforms for their OT/IT networks to run white-listing, traffic pattern monitoring, protocols and packet inspection and security policies. The platforms must feature robust design, optimal performance and well-configured I/O connectivity to fulfill security requests in the challenging environments.

### MOST TARGETED INDUSTRIES (GLOBAL)

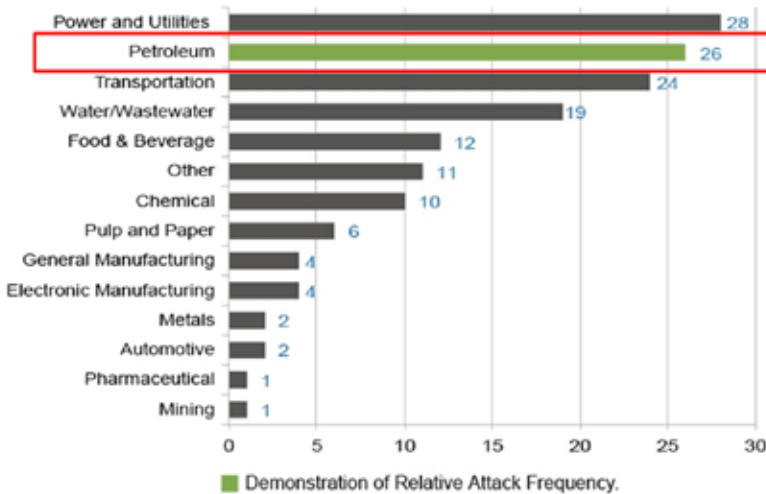

Source: Repository of Industrial Security Incidents/Security Incidents Org.

## Key Application

- Protocol filtering
- Access detection
- Packet inspection
- White-listing
- Network traffic monitoring.
- Data encryption and decryption
- LAN Bypass



# Integrating Multi-Layer Architectures to Mitigate Cyber Vulnerabilities in Oil and Gas Sectors

## Cyber-security in OT Network

To implement security measure and prevent unauthorized remote access, LEC-6032 is a compact, 24/7 industrial firewall designed for oil and gas sectors. The rugged LEC-6032 is compliant with in Class 1 Division 2 certification against hazardous environments with possible volatile or flammable gases or vapors. Its fanless design reduces system outages and minimizes dust inside the device. LEC-6032 also boasts an extended operating temperature with a maximum range of -40 °C to 70 °C. This provides the wide operability under harsh ambient environments at ICS deployed sites.

## Cyber-security in DMZ Networks

Designed to defend advanced cyber attacks (such as DDoS attack) at historian servers and domain controllers in the industrial DMZ, Lanner's NCA-4210 is empowered by the new Intel 14nm micro-architecture CPU, the 6th generation Intel® Core™ processor (codenamed Skylake-S).

## Cyber-security in Enterprise Networks

Built for protecting enterprise networks, Lanner provides the FW-8896, the high-performance enterprise network firewalls with high availability and reliability. This 2U rackmount x86 network appliances is equipped with the dual Intel® Xeon® E5 2600 v3/v4 CPUs/C612 chipset (codenamed "Grantley") and DDR4 registered DIMM memory up to 2133 MHz frequency for delivering unmatched computing power for implementing advanced security measures.

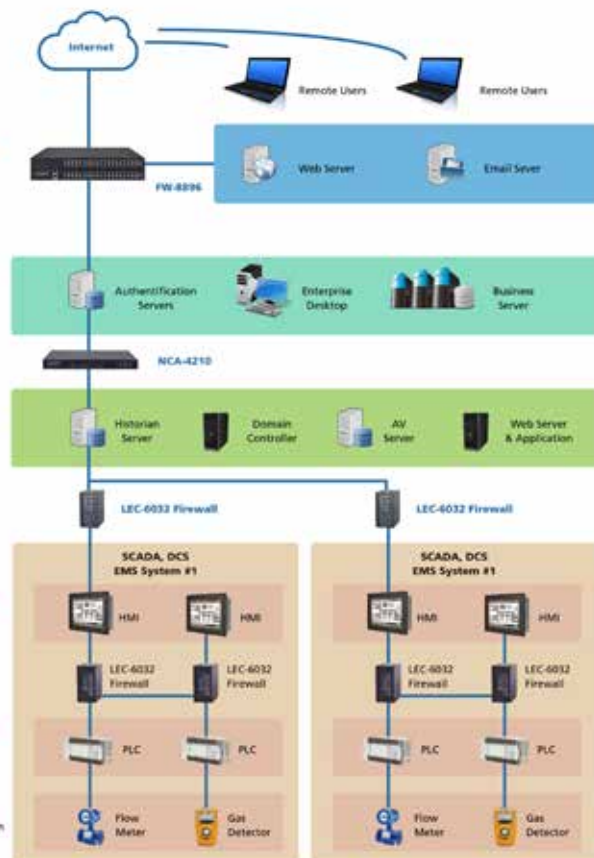

## Featured Products

**LEC-6032**



**NCA-4210**



**FW-8896**



# Industrial Cyber Security

## Background

Traditionally, industrial control systems (ICS) like SCADA system used to be isolated for its sole purpose of performing mission-critical tasks. However, with the increasing complexity in hardware design and the implementation of open network due to convenience and cost-effectiveness, ICS environments are vulnerable towards cyber threats. The reports indicated that hackers usually attack the weak sides of DCS (distributed control systems), PLC (programmable logic controllers) and HMI (human machine interface) through unauthorized remote accesses, non-inspected packets, lack of protocol scanning and filtering as well as loose authentication process.

## Lanner Solution

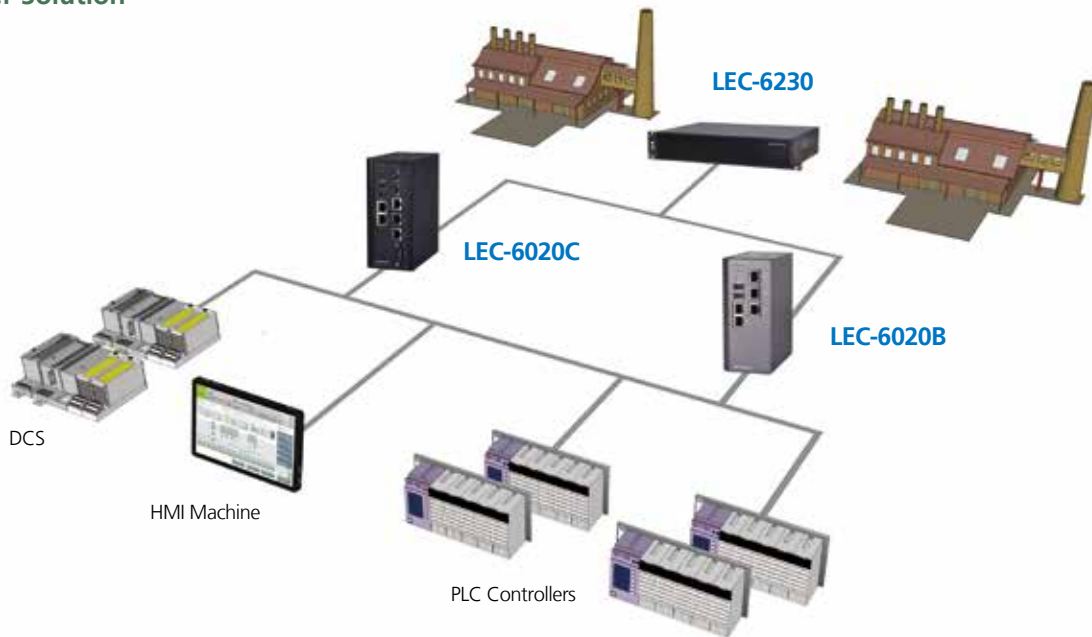

As shown in the diagram above, LEC-6020B/LEC-6020C act as the gateway controllers to perform white-listing, protocol filtering, and access detections for the networks that bridge PLCs/HMIs/DCS with the infrastructure. These gateway controllers will deeply inspect the packets traveling through its monitored network protocols. In addition, these control platforms can be programmed to conduct white-listing, which restricts the access to unrecognized individuals. In that case, the protocols are protected against unauthorized applications and even potential malware that might devastate the whole operations.

In a more advanced implementation, LEC-6230 acts as the main control center to perform encryptions while LEC-6020s will function as the decryption stage. LEC-6230 acts as the main control center to perform encryptions while LEC-6020s will function as the decryption stage. With encryption, data and information flowing in this protocol will be "transformed" into meaninglessly unreadable random logs to those without the decryption key. This will secure the transmission among devices in ICS and SCADA systems.

## Key Application

- Protocol filtering
- Access detection
- Packet inspection
- White-listing
- Network traffic monitoring.
- Data encryption and decryption
- LAN Bypass

# Industrial Cyber Security

## Benefits



### IEC 61850-3 and IEEE 1613 compliant

Measured and certified for use in industrial condition such as power substation



### Customizable I/O sections

Flexible I/O ports selections and Ethernet modules for easy customization



### ESD/Surge protection

Strong built-in EMC protection to cope with harsh environment



### Fanless Design

Without the most frequently replaced part, the systems can be widely deployed in various environments.

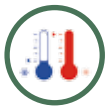

### Wide Temperature Range

Withstand in challenge conditions with temperatures as low as -40 to 70°C



### Dual Power Inputs

Provide redundant power supply when main power source fails



### LAN Bypass

Allow uninterrupted network traffic even if a single device is down



### Advanced Secure Function

Support security functions such as TPM and BIOS Lockup

## Featured Products



LEC-6020

### Fanless Industrial DIN Rail Security Platform with Intel® Atom™ N2600 CPU

- Intel® Atom N2600 processor with NM10 chipset
- DDR3 memory, maximum capacity is 2 GB
- Fanless design with corrugated aluminum
- Wide temperature range (-40~70°C)
- 15KV ESD and surge protection on Serial COM ports
- 3 or 5 Intel GbE LAN ports with 15KV magnetic isolation protection
- Flexible I/O selections (LAN/USB/Serial COM/Phoenix Contact)
- 1 or 2 pairs of LAN Bypass
- Dual power input (12~36Vdc)
- DIN-rail mount and wall mount



LEC-6230

### IEC 61850-3 certified 2U Rackmount Security Appliance with flexible I/O Module Design

- Intel Core i7-3217UE processor with HM65 chipset
- DDR3 memory, maximum capacity is 8 GB
- Fanless design with corrugated aluminum
- IEC 61850-3 & IEEE 1613 compliant
- Wide temperature range (-20~55°C)
- Rich and expandable modules for flexible Ethernet connectivity
- ESD and surge protection on Serial COM ports
- Intel GbE LAN ports with magnetic isolation protection
- Rich I/O: 2 Serial COM, 2 USB port, 1 VGA port
- Optional Gen.1 LAN Bypass function

# Solar Power Monitoring

## Background

One of China's electric companies sent out a request for hardware solutions capable of monitoring solar power substations located at unmanned, remote areas with harsh climates. The requested system was to be developed into an integrated communications platform for gathering, storing and analyzing data relating to sunlight strength, direct current power, power conversion efficiency, array disconnect statistics and overseeing meters such as wind speed and temperature. The collected data would be uploaded instantly to an operation center via the serial-to-Ethernet communication.

## Lanner Solution

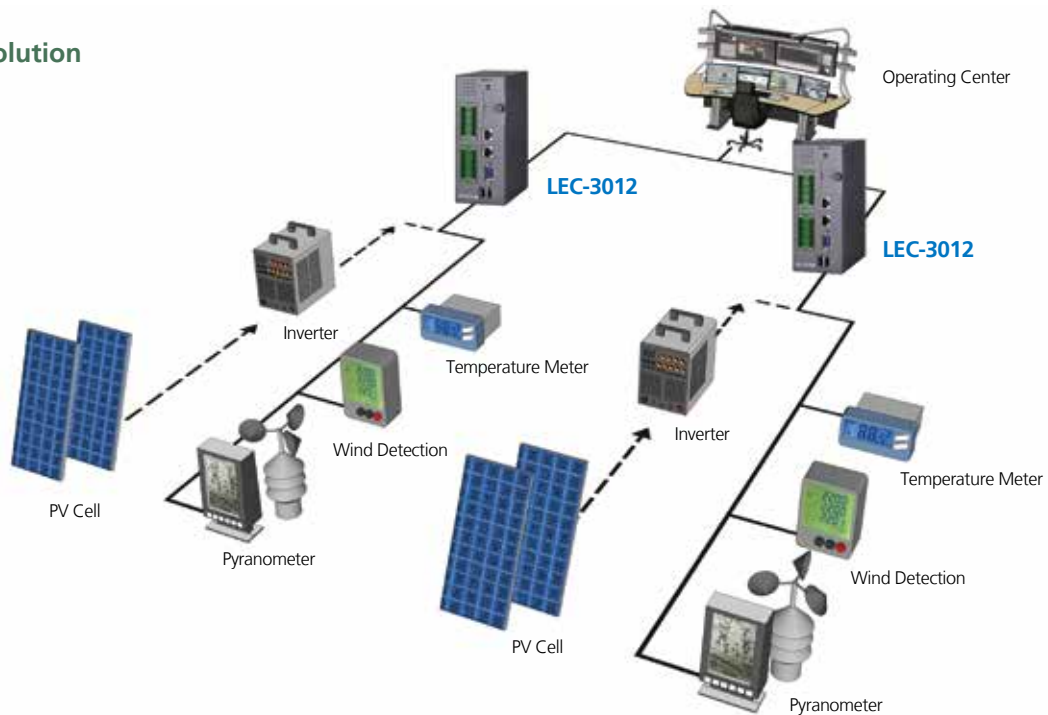

Lanner's LEC-3012, a robust and compact IPC was eventually selected as the data concentrator for the aforementioned solar power monitoring system capable of gathering and analyzing data from sensors and meters deployed at the remote site. LEC-3012 features Intel Atom N455 CPU, 4 Serial COM ports with 15KV ESD/surge protections and 2 GbE LAN ports with magnetic isolation protections; such configuration makes possible an integrated setup on which reliable communications with inverters for overseeing the DC to AC conversion efficiency can be developed. LEC-3012 also features 2 x 10 terminal block function for the Serial COM ports, providing a multitude of wiring options adaptable for various types of sensors and meters. LEC-3012's solid chassis and fanless design are two critical factors for a remote site industrial communication device. Furthermore, the DIN rail mount and front access ports simplify hardware maintenance as service can be carried out while the appliance was still mounted.

## Key Application

- Solar Photovoltaic Monitoring System
- Data Concentrator
- Wind Turbine Vibration Monitoring System
- Wind Power Field Monitoring System



# Solar Power Monitoring

## Benefits



### ESD/Surge protection

Strong built-in EMC protection to cope with harsh environment

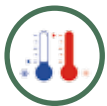

### Wide Temperature Range

Withstand in challenge conditions with temperatures as low as -40 to 70°C



### Low Power Consumption

Many of our industrial box PCs use low power Intel® Atom™ processor with 13W, 6.5W or even only 3.5W TDP (Thermal Design Power).



### Diversified I/O sections

Various I/O options, including multiple COM, LAN, USB, CF, VGA and Phoenix Contacts connectors.



### Advanced Secure Function

Majority of our industrial platforms are designed with DIN-Rail mounting option for convenient installation in industrial environments.



### Fanless Design

Without the most frequently replaced part, the systems can be widely deployed in various environments.

## Featured Products



LEC-3013-I10

### 10 Serial Port Fanless DIN Rail Box PC with Intel Atom D525

- Intel® Atom™ Dual Core D525 processor with ICH8M chipset
- DDR3 memory, maximum capacity up to 4GB
- 10 Serial COM ports with ESD and surge protection
- Fanless design with corrugated aluminum
- Wide temperature range (-20~55°C)
- 15KV ESD and surge protection on Serial COM ports
- Rich I/O selections (4 x USB 2.0, 1 x VGA)
- 2 Intel GbE LAN ports with magnetic isolation protection
- Storage: 1 x CF card slot and 1 x SATA port



LEC-3012A

### Fanless Industrial DIN Rail Box IPC with Intel® Atom™ N455 CPU

- Intel® Atom™ N455 processor with ICH8M chipset
- DDR3 memory, maximum capacity up to 2GB
- Fanless design with corrugated aluminum
- Wide temperature range (-20~55°C)
- ESD and surge protection on Serial COM ports
- 2 to 4 Intel GbE LAN ports with magnetic isolation protection
- Flexible I/O: 4, 6, or 8-port serial COM or 2, 4 Gigabit Ethernet ports
- Storage: 1 x CF card slot and 1 x SATA port



## Background

Since the trend of IoT (Internet of Things), energy sectors all over the world have been frequently the main targets for deliberate malware as consequences of planned attacks can highly devastate reliability, serviceability and public trust. One of the recent incidents was the power cut during Christmas season in Ukraine, 2015, followed by a series of cyber attacks to local energy companies. Large parts of the state were under power black-out. This incident revealed that ICS systems today are practically vulnerable to deliberate attacks.

The main reason of such vulnerability is the adoption of mainstream hardware and standard operating systems. These IT equipments are implemented for increased automation; however, they are so common that professional attackers are very familiar with their weakness. In addition, most of the security measures for ICS (Industrial Control System) and SCADA today are still traditional and old-fashioned against modern attacks because these were built before advanced malwares.

The accumulated incidents have served as a warning sign that there is a need for more sophisticated, multi-layer prevention measure in order to protect energy sectors from deliberate malicious attacks like spear-phishing and social engineering made common due to IoT and cloud computing.

## Lanner Solution

Lanner's LEC-6032 is purposely made to address the cyber threats targeting on energy sectors. LEC-6032 is driven by Intel® Atom™ E3845 1.91GHz SoC CPU, a low power consumption processor with steady performance for network traffic management. In addition, the CPU is programmed with AES-NI (Advanced Encryption Standard – New Instruction), virtualization technology as well as Execute Disable Bit to reinforce system security and network defense. The CPU is scalable for instruction and policy implementation to detect unauthorized behaviors and malware, as well as conduct validation and authentication processes.

LEC-6032 comes with multiple LAN ports and SFP ports for Ethernet connections with other networked devices like PLCs, HMIs or SCADAs. Once connections established, LEC-6032 can act as the firewall/UTM in the center to monitor and control the network traffic of the operating environment. Besides, some LAN ports of LEC-6032 provide PoE (Power-over-Ethernet) and bypass functions to ensure serviceability.

By taking ruggedness into consideration, LEC-6032 is built with Magnetic Isolation Protection up to 1.5 KV for LAN ports and ESD Protection up to 15KV for other I/O ports to prevent electrical and ESD surges. In addition, LEC-6032 supports wide operating temperature -40~70°C and dual power inputs as required for deployment in energy sectors.

## Key Application

- Power Plant Cyber Security
- Factory ICS Cyber Security
- Industrial UTM/Firewall
- Oil & Gas Security Gateway
- SCADA Network Security



## Benefits

Although there are many computing solutions available, they are all made of mainstream hardware and OS, which are easy for attackers. What's really needed is a reliable platform solely oriented to provide visibility and detection to unauthorized behaviors over the whole network system, including Internet, Intranet, DNPs, private cloud and corporate VPNs. The platform must reinforce potential blind spots or loop holes such as network traffic, local device, or even human beings. It must be able to detect all unauthorized changes to hardware, software and firmware. A practical solution is to implement a hardware firewall/UTM with the following requirements to conduct security measures:

### Performance and Power Balanced Processor

Due to the heavy loading of control activity over the ICS network, the firewall should be engineered with a low-power and reliable performance CPU to conduct prevention policies and instructions.

### Multiple Ethernet Connectivity

As the firewall is connected to operational technologies like PLCs, HMIs, and SCADAs, there should be multiple LAN ports for network connections in order to conduct monitoring. In fact, it is even more ideal if the LAN port can supply power as industrial environments sometimes lack of stable power supply.

### ESD and Surge Protection

It is possible that power surge may take place in the energy operation environment. Therefore, the required firewall must be built with some degree of protection for its I/O ports.

### Wide Operating Temperature

Extreme temperatures may be encountered in energy operation environments; therefore, the firewall must be able to work under wide operating temperature.

## Featured Products

### LEC-6032 Series



### Industrial cyber security PC with Intel Atom E3845 CPU and advanced LAN bypass

- Fanless and compact design
- Intel® Atom™ E3845 1.91GHz SoC CPU
- Wide Temperature Support: -40~70°C
- 6032C with 2 x GbE SFP Fiber, 6032F with 4 x GbE SFP Fiber
- ESD/surge protection on serial COM ports for harsh environments
- 3 or 5 x GbE LAN with 1 or 2 pair Gen.3 LAN bypass
- DIN rail or wall mounting options
- 1 x USB 3.0 and 1x USB 2.0 port



## Background

To reduce carbon emission, renewable energy has become one of the most discussed subjects regarding utilities. Among these, solar energy is the most anticipated source of renewable energy. In fact, many countries have already implemented solar PV plants in communities, commercial areas and industrial zones.

However, solar energy is expensive when comparing it to the conventional ways of generating power. This results in higher overheads and thus the cost has been the major concern in the global energy market. Since costs are highly concerned, businesses are looking for ways to evaluate their return on investments and how efficient and valuable their assets can be. One of the most practical ways is to adopt a monitoring system by the solar PV plants to monitor the data for performance measurement.

## Lanner Solution

To meet the technological requirements above, Lanner introduces LEC-3030 as the commercial solar PV monitoring hardware solution. LEC-3030 is the ideal gateway control system and data control and monitoring in such applications due to its data processing ability, compact size and protected LAN and COM connectivity.

As an effective solar PV monitoring system, LEC-3030 performs reliably in data collections. With the architecture of Intel Celeron N2807 dual-core SoC CPU and 4GB DDR3L SO-DIMM data memory, LEC-3030 can execute data logging and control of current, inverter data, weather information, and other parameters. The collected information will serve as important feedbacks or references to system owners/investors.

LEC-3030 can provide reliable data exchange through its protected protocols. The Ethernet LAN ports of LEC-3030 are protected by 1.5KV magnetic isolation protection to ensure solid data transfer in demanding environments. The serial COM ports of LEC-3030 are also protected. Since COM ports are important field bus with other grid-peripherals such as inverters and meteorological devices, the COM ports are protected by 2KV digital isolation and 15KV ESD protections to ensure the communications with other devices.



## Key Application

- Solar PV Monitoring
- Data Concentrator
- Wind Turbine Energy Monitoring System
- Greenhouse Management



Another important aspect is that LEC-3030 comes in a highly compact form factor. With the growing emphasis in space and performance balance due to concerns about cost, LEC-3030 is the optimal choice in commercial solar PV monitoring applications. Since solar plants are usually exposed to high amount of sunlight and perhaps extreme temperature, LEC-3030T is built with wide temperature at the range of -40 ~70°C.

## Benefits

### The Need for Monitoring and Control

At commercial level, it is highly crucial to determine the actual performance of the solar PV monitoring system so that investors or owners can analyze the values of their invested implementations. Thus, an effective monitoring system requires consistent, reliable and traceable data monitoring capability in order to optimize the return on investment during the lifetime of the system. There are technological and systematic requirements to fulfill the capability.

### Data processing

The required monitoring system will function as the controller of the PV plant and will be independent from the inverters. The system will collect and control information including voltage, inverter status, weather conditions, and power setting. Therefore, reliable data processing capability is required in order to acquire precise data which acts as feedbacks to owners and investors alike.

### Protected Ethernet and COM Connectivity

Since Ethernet is the main protocol for data transfer within the network, the Ethernet ports must be protected when the system is deployed in potentially demanding environments. Protections are also required for serial COM ports as they are the main field bus for inverters and weather condition reporting devices.

### Compact Form Factor

With cost and space efficiency concerns, compact size and small form factor are preferred options for investments.

### Environmental Endurance

Solar PV plants are sometimes implemented in demanding environments so that the system must be able to operate under wide range of operating temperature.

## Featured Products

### LEC-3030 Series



### Compact Industrial Grade DIN Rail Box PC with Intel® N2807/E3815 Processor

- Compact-sized industrial grade box PC
- Dual-core Intel Celeron N2807 SoC CPU or Single-core Atom E3815
- ESD/surge protection on serial COM ports for harsh environments
- Wide operating temperature (LEC-3030T:-40~70°C)
- Fanless design with corrugated aluminum
- Support VGA display output
- DIN-Rail or wall mounting options
- Support 4x DI/O
- Dual GbE LAN ports, 1 x USB 2.0, 1 x USB 3.0 port
- 1 x SATA port



## Background

Utility institutions today are operating globally and relying on substation automation systems to have a secured and reliable solution for controlling and monitoring status of the substations and grids. Historically, substation automation structures involve multiple proprietary protocols which consist of numerous remote thermal units, PLCs, HMIs and plenty of computing systems to be wired together. This implementation usually results in heavy hardware investment, high engineering development time and high maintenance costs due to wiring redundancy and customized communication protocols. In fact, there could be compatibility issues among the automation devices from different vendors.

### IEC 61850

IEC 61850 was introduced to offer power companies a globally standardized communication protocol for substations automation systems. The standard comes with a promise to provide open-architecture, flexibility, interoperability, future-proof and reduced wiring costs while eliminating possible compatibility issues among devices from various suppliers.

## Lanner Solution

Lanner's Robust, Rich I/O and High-Processing Communication Platform

Lanner's LEC-3231 is the optimal substation gateway solution designed with industrial-grade robustness, rich I/O options, and high CPU performance for status monitoring and message filtering. The rugged, fanless box PC is driven by processor choices of Intel Celeron 847E, Core i3-3217UE or Core i7-3517UE, depending on the SKU selected, and also supports up to 10 isolated COM ports, 8 magnet isolated LAN ports, and redundant power supplies. To function as a safe and secured platform, LEC-3231 is compliant with IEC-61850-3 standard and supports wide operating temperature of -40 to 70°C for substation automation applications.

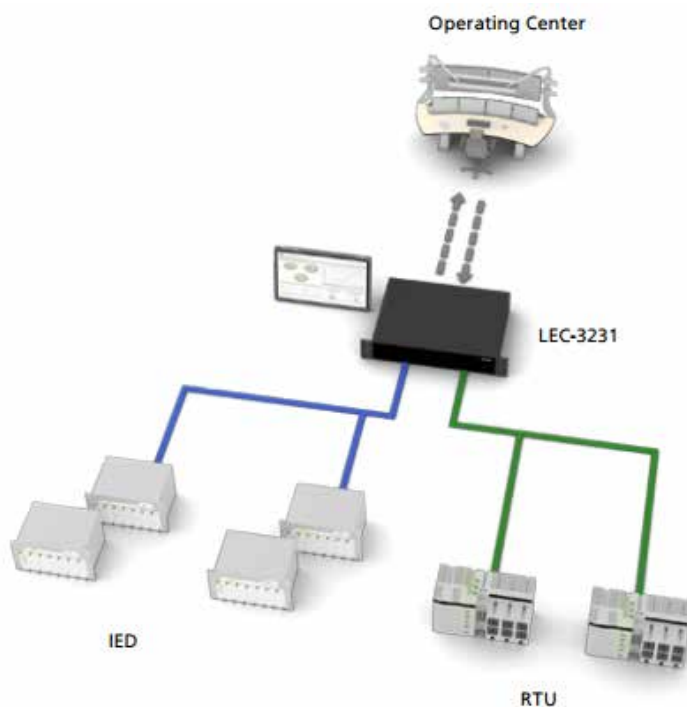

## Key Application

- Power SCADA System Communication Gateway
- Automation Platform for Substation
- IED Communication Gateway



LEC-3231 is driven by Intel Celeron 847E, Core i3-3217UE or Core i7-3517UE CPU (codenamed Ivy Bridge/Sandy Bridge) to deliver high-performance for automation systems to run on grid-messaging software like GOOSE or GSSE. For low power consumption, the SKU with Intel Celeron 847E is the ideal choice, whereas the models with Core i3/Core-i7 are designed for high-performance boost, virtualization technologies and security instruction sets.

As a highly reliable communication gateway in substation automation, LEC-3231 is compliant with IEC 61850-3 and supports wide operating temperature from -40 to 70°C , enabling the device to work under harsh environments. In addition, LEC-3231 provides the high-availability of redundant power supplies with particular options: 36 to 48 Vdc or 90 to 246 Vdc/100-300 Vdc, to deliver the sufficient power power in harsh environments.

In terms of the rich I/O design, the fanless box PC comes with two DB-9 COM ports and one 2x2x5 terminal block to provide RS-232/422/485 functionalities for connections with other industrial equipments. The serial I/Os are coated with 15KV ESD Protection. Regarding network connectivity, LEC-3231 supports up to 8 magnetic isolated LAN ports to enable connections with other networked devices for local and remote communications.

For future-proof scalability, LEC-3231 can be added with more I/O modules to connect with more automation devices. LEC-3231 supports a wide range of serial port and LAN port modules to further expand its I/O connectivity. The I/O modules are to serve customizable demands for specific applications.

LEC-3231 is also applicable in IED and SCADA communication gateways.

## Benefits

The standard of IEC 61850 has shortened engineering development time and cost, by defining the software and hardware requirements. There are already mainstream grid-oriented software programs like GOOSE and GSSE, deployed by many power companies in the world. In terms of hardware requirements, system performance and environmental reliability are two major considerations to function as a status-monitoring gateway in harsh environments like grids and substations. Other factors include input/output designs, ESD/surge protections and networking connectivity.

- High computational power
- IEC 61850 compliance
- Protected serial COM I/O
- Future-proof Scalability
- Wide operating temperature
- Rich LAN ports
- High availability and reliability

## Featured Products

### LEC-3231



### IEC 61850-3 Compliant Rackmount Box PC with RPS

- IEC 61850-3 and IEEE 1613 compliant
- Support Intel Celeron or Core i3/i7 CPU
- Optional redundant power supplies
- Rich, flexible and expandable I/O interface
- Wide temperature range (-40~70°C)
- ESD and surge protection on serial ports
- Support 1333/1600MHz DDR3 memory up to 8GB
- Fanless design with corrugated aluminium
- Support VGA port