

# LUGE: EM-F345

Fanless Intel® Atom™ 1.6Ghz embedded system with VGA, DVI-D, Dual LAN, USB, COM with CompactFlash and SATA drive support

VGA

DVI-D

LAN

USB

CF

SATA

COM

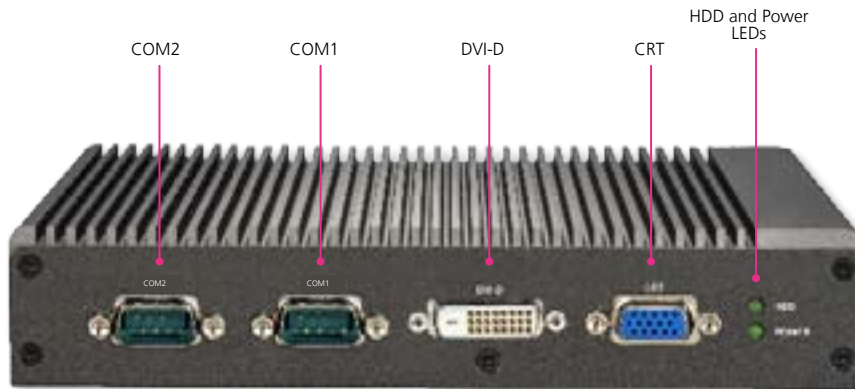
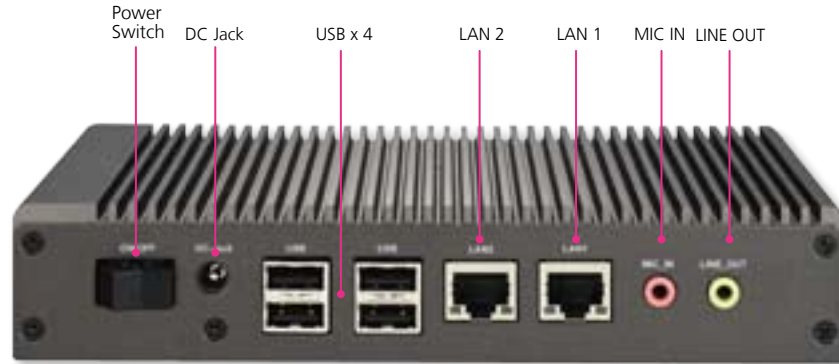

## FEATURES

- Intel® Atom™ 1.6 GHz onboard CPU
- Robust fanless enclosure
- Slim 36mm case with heat dispersing fins
- -20°C to 50°C operating temperature
- Supports up to 2GB DDR2 memory
- Dual Display (CRT+DVI-D)
- Dual 10/100/1000 Mbps LAN
- USB x 4, COM x 2
- CompactFlash Type I/II and SATA HDD support
- Optional Wall, VESA, DIN or Rack mounting brackets

## FLEXIBLE MOUNTING AND DEPLOYMENT OPTIONS

The EM-F345 is designed for flexible deployment in any scenario. Its robust fanless design makes the EM-F345 an ideal solution for video applications such as digital signs, outdoor advertising and kiosk systems.

The onboard Intel® Atom™ embedded processor provides unsurpassed performance with very low heat generation and minimal cooling requirements, resulting in improved stability and longevity, and providing a higher return on investment.

To provide even more flexibility, Lanner's engineers have built the case of tough aluminum with heat dispersing fins to whisk away heat from the processor and allow the system to operate in harsh environments - from -20°C to 50°C. Whether you need a machine for digital signage, ATM, POS, or a factory controller, the EM-F345 is built for the task.

**DVI-D**

**FEATURE DESCRIPTION**

<b>Platform</b>	Processor	Onboard Intel® Atom™ 1.6 GHz
	Chipset	Intel 945GSE+ICH7M
	BIOS	AMIBIOS with 8Mbit BIOS Flash
<b>System Memory</b>	Technology	DDR2 400/533 SDRAM
	Maximum Capacity	2GB
	Socket	200P SODIMM x1
<b>Storage Interface</b>	CompactFlash I/II	1
	SATA Port	1
<b>Networking</b>	LAN Ports	2 (RTL8111C-VC-VR)
	Speed	10/100/1000 Mbps
<b>Display</b>	Controller	Intel GMA 950
<b>Audio</b>	Codec	ALC888 HD Codec
	Serial	2 ports (RS-232)
<b>Front I/O</b>	VGA	1 (Max. Res. 2048 x 1536)
	DVI-D	1 (Max. Res. 1600 x 1200)
<b>Rear IO</b>	Power in	DC Jack
	USB 2.0	4
	LAN	RJ45 x 2
	Mic In / Line Out	1 / 1
<b>Expansion</b>		Mini-PCI socket
<b>Hardware Monitoring</b>	Controller	Winbond W83627UHG integrated hardware monitor
	Watchdog timer	Yes (255 levels, 0 - 255 Sec)
<b>OS Supported</b>		Win XP Embedded, Win XP 32-bit, Win 2000, Linux kernel 2.4.16 or above
<b>Environmental Parameters</b>	Temperature, ambient operating	-20°~50°C (with industrial components - CF card, memory, adapter)
		0~40°C (with 2.5" HDD)
	Humidity (RH), ambient operating	5~95% relative humidity, non-condensing
	Storage Temperature	-20°~70°C (-4°~158°F)
<b>Mounting</b>		Optional wall mounting kit
		Optional VESA mounting kit
		Optional DIN-RAIL Kit
		Optional Rack mounting kit
<b>Physical Dimensions</b>	Dimensions	145D x 190W x 36H mm
	Weight	1.07Kg
<b>Power</b>	Input	DC +12V, AT Only
	Power Adapter	60W, 100 ~ 240 VAC input
<b>Compliance</b>		CE, FCC, RoHS

**ORDERING INFORMATION**

**EM-F345** Fanless Embedded System with Intel Atom 1.6 GHz CPU onboard, CF Socket, 2.5" SATA HDD Support

**DIMENSIONS**

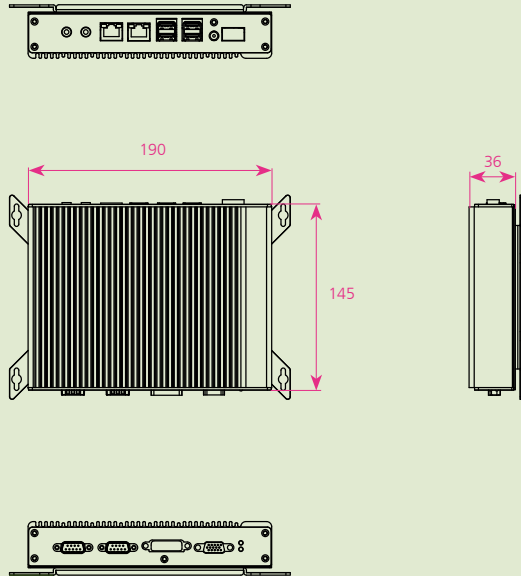

**About Lanner**

Founded in 1986 and publicly listed (TAIEX 6245) since 2003, Lanner Electronics Inc. is an ISO 9001 certified designer and manufacturer of reliable, frontline security, storage and applied computing platforms and solutions. With headquarters in Taipei, Taiwan and branches in the U.S. and China, Lanner is uniquely positioned to deliver custom technical solutions with localized, value-added service.

**Contact information**

Lanner Electronics Inc  
7F, 173, Section 2 Datong road  
Sijhih City, Taipei County 221, Taiwan

**T** +886 2 86926060

**F** +886 2 86926101

**E** sales@lannerinc.com

**W** www.lannerinc.com